

LISTEN.  
THINK.  
SOLVE.®

# Energy Efficiency

Take control of your energy usage

Summer Days, September 2015

Velké Karlovice



PUBLIC INFORMATION



Allen-Bradley • Rockwell Software

**Rockwell  
Automation**

# Energy Management

Manage energy consumption throughout the plant

**Rockwell  
Automation**

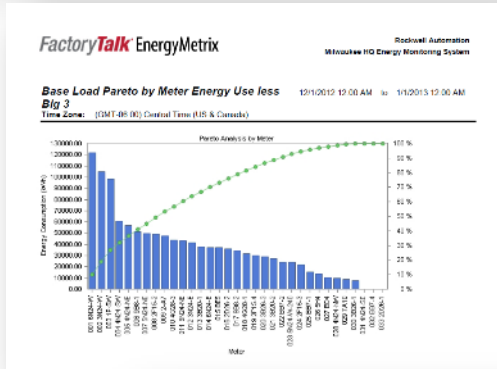

**test load factor**  
Time Zone: (GMT-05:00) Central Time (US & Canada)

Day	Min. Demand	Avg. Demand	Max. Demand	Load Factor	Time of Peak Demand
01	343.5	351.4	359.6	0.98	23:45
02	342.5	355.2	360.1	0.99	02:45
03	348.0	356.4	361.2	0.99	19:30
04	323.4	351.6	355.9	0.98	12:00
05	307.2	323.2	333.7	0.97	23:15
06	328.1	349.9	352.1	0.97	23:30
07	329.2	339.2	352.0	0.96	00:45
08	322.0	328.7	335.8	0.98	21:00
09	321.3	329.6	340.3	0.97	01:30
10	312.2	323.6	336.1	0.96	00:30
11	313.7	321.6	330.0	0.97	18:15
12	318.8	325.6	340.4	0.98	15:30
13	328.2	339.7	351.3	0.97	14:00
14	320.4	340.0	350.7	0.97	16:00
15	342.7	348.2	351.5	0.98	20:15
16	337.9	344.7	352.3	0.98	03:00
17	312.0	331.2	344.8	0.96	06:30
18	313.4	322.3	333.6	0.97	19:30
19	316.4	324.6	333.2	0.97	22:00
20	320.5	330.1	341.3	0.97	12:15
21	294.2	311.5	332.5	0.94	02:30
22	293.8	308.0	325.2	0.95	16:30
23	294.2	303.6	315.9	0.96	13:45
24	286.9	307.5	317.7	0.97	06:15
25	291.6	299.8	316.2	0.96	08:00
26	308.3	320.3	335.3	0.96	16:45
27	320.3	328.4	331.4	0.98	13:15
28	324.7	330.6	338.7	0.98	18:30
29	307.0	323.4	333.0	0.97	02:00
30	304.8	318.7	332.4	0.95	00:00
31	304.6	323.3	341.3	0.95	06:15

Printed 1/18/2013 8:09:35 AM Page 1 of 2

Real Energy	Reactive Energy	Power Factor
71,200.2	31,253.3	-0.52
71,023.2	30,483.4	-0.52
88,612.4	33,204.1	-0.54
88,434.4	35,028.2	-0.53
83,697.7	22,230.0	-0.54
87,659.2	33,696.6	-0.53
87,416.3	34,428.5	-0.53
72,713.0	30,318.9	-0.52
70,980.2	29,492.1	-0.52
79,479.6	27,666.2	-0.54
79,563.0	27,038.6	-0.58
86,400.6	31,570.1	-0.54
87,197.6	33,889.6	-0.53
89,459.4	36,254.4	-0.53
71,695.2	31,644.2	-0.51
71,513.4	30,899.3	-0.52
79,984.9	27,227.5	-0.55
60,458.1	28,745.9	-0.54
78,990.1	26,740.3	-0.55
84,623.6	33,686.1	-0.53
83,722.0	32,798.6	-0.53
49,788.1	30,155.8	-0.52
69,342.9	29,929.4	-0.52
72,668.8	30,880.9	-0.52
72,479.6	30,345.8	-0.52
82,071.5	32,048.9	-0.53
63,758.8	32,224.3	-0.53
81,641.1	32,962.2	-0.53
71,390.4	29,941.6	-0.52

Printed 1/18/2013 8:07:41 AM Page 1 of 2

**Meter Setup**

Type: Electric  
Device: 1P-SW  
Name: C Meter PFZT 1100 Bldg 51  
Assigned to Groups (Contribution factor %): 1 WE Electric Mains (100)

ID	Type	Name	Units	Log Rate	Address
199	Device	Real Energy Net (Status Input 1 Counter)	kWh	15 minutes	38.9
200	Derived	Real Power Demand	kW	15 minutes	38.9

**Reports**

Time zone: (GMT-06:00) Central Time (US & Canada)

Date/Time	Real Energy Net (Status Input 1 Counter) (kWh)	Real Power Demand (kW)
1/18/2013 7:45 AM	22576.3	858.2
1/18/2013 7:30 AM	22361.8	829.4
1/18/2013 7:15 AM	22154.4	823.7
1/18/2013 7:00 AM	21948.5	800.6
1/18/2013 6:45 AM	21748.3	789.1
1/18/2013 6:30 AM	21551	794.9
1/18/2013 6:15 AM	21352.3	789.1
1/18/2013 6:00 AM	21155	783.4
1/18/2013 5:45 AM	20959.2	766.1
1/18/2013 5:30 AM	20767.7	777.6
1/18/2013 5:15 AM	20573.3	766.1
1/18/2013 5:00 AM	20381.8	754.6
1/18/2013 4:45 AM	20193.1	743
1/18/2013 4:30 AM	20007.4	731.5
1/18/2013 4:15 AM	19824.5	731.5



# Agenda

Introduction to Energy Management

PowerMonitors, FactoryTalk EnergyMetrix and E300

FT EnergyMetrix Demonstration

Summary and Q & A



# Business Challenges

## Cost Volatility

- Reduce costs
- Maintain Competitive Advantage
- Predictability of prices

## Supply Scarcity

- Resource constraints
- Energy reliability and availability

## Government Regulations

- Compliance to current and future regulations

## Sustainability

- Corporate initiatives
- Brand protection

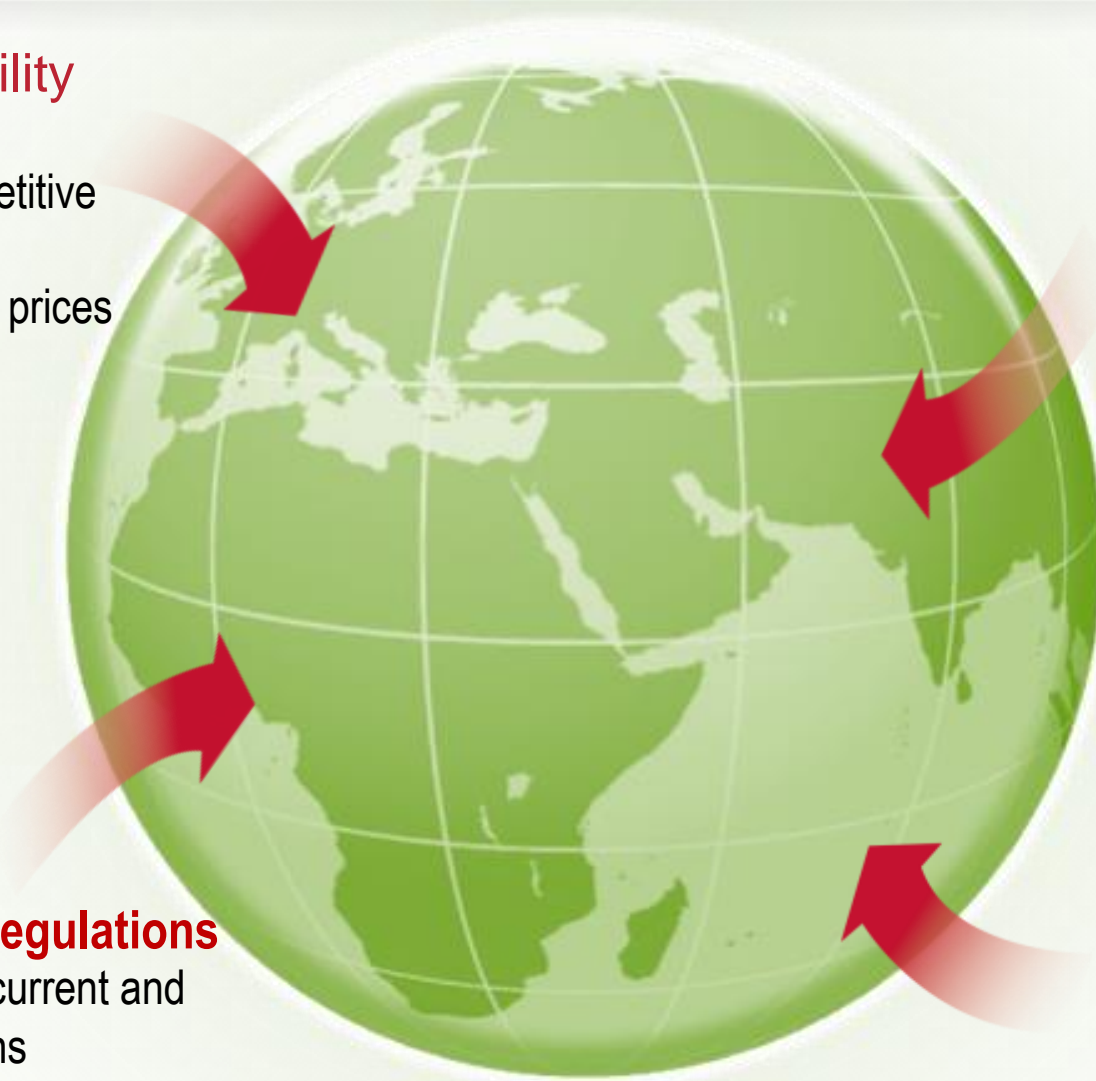

# Business Drivers



Lower CO2 Emissions



Minimize Risks



Increase company performance



Cost transparency



Lower Energy Cost



Energy Efficiency

Lower Energy Cost

# How are you Managing your Energy Usage?

**Rockwell  
Automation**

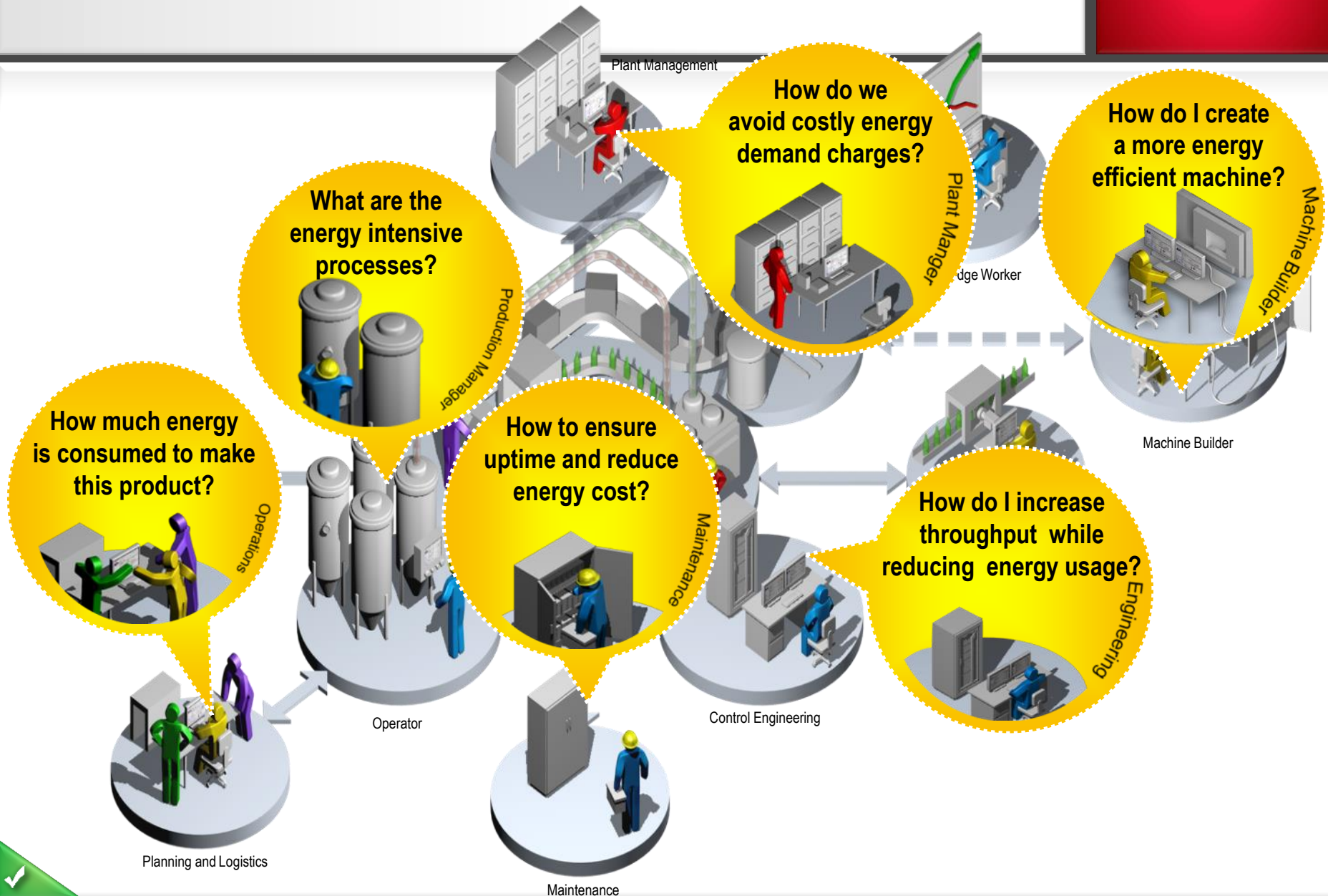

# Pressure Points Driving Focus on Energy

- Energy price volatility impacting profitability
- Regulatory pressures
- Resource competition and political instability keep prices high and unstable
- Stakeholder pressures for sustainability

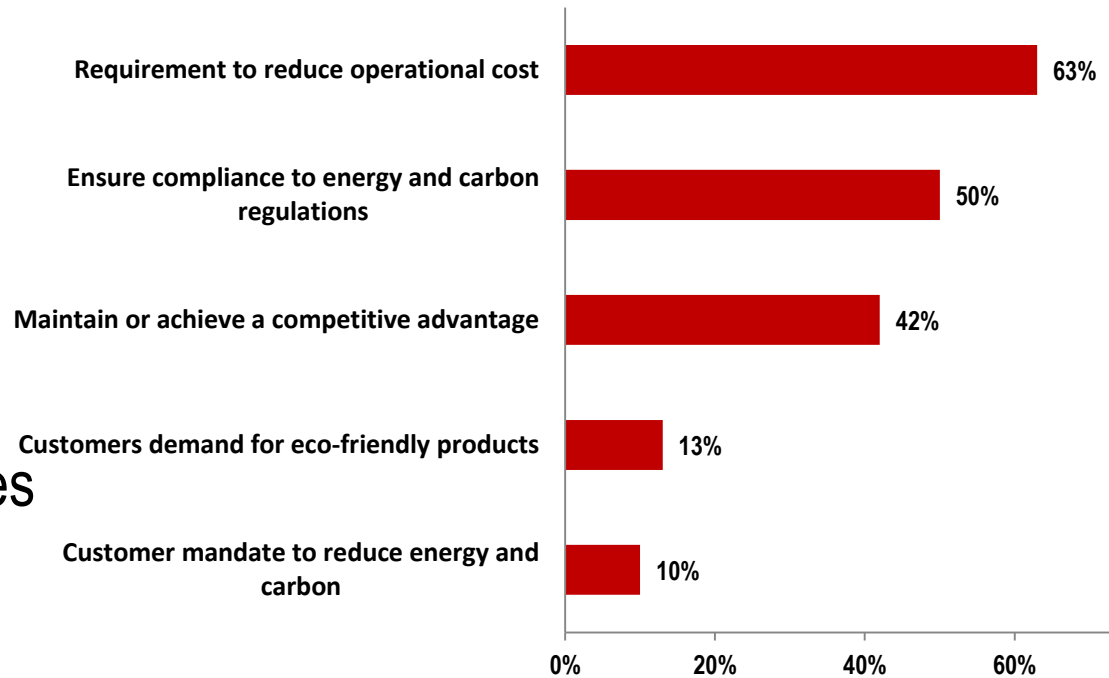

Aberdeen Group Report 2012

***Energy cost can no longer be considered overhead.  
It must be included as part of the cost of manufacturing***

# The Pressure to Improve Productivity

How your control system can help

Rockwell  
Automation

*To improve productivity, you need **actionable** information.  
Your control system contains a hidden wealth of information.*





# Understand What You are Paying for

- Components of an Energy Tariff
  - Consumption charges
  - Demand charges (electrical only)
  - Quality charges (power factor, BODs, etc.)
  - Taxes
  - Contribution to energy conservation programs
- Rates vary depending on:
  - Amount used
  - Time of Day
  - Day of Week
  - Season
  - Real-time markets



***You can't control what you don't understand!***

# Rockwell Automation Energy Management Portfolio

**Rockwell  
Automation**

## Energy Monitors



*PM 500*



*PMW250*



*PM 1000*



*PM 3000*



*PM 5000*

CIP  
Energy

## Power Control



*PowerFlex Drives*



*Intelligent Motor Control*



*Power Control Components*



## Information

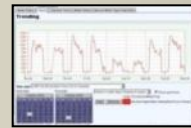

*FTEnergy Metrix*



*VantagePoint*



*Pavilion*

## Solutions

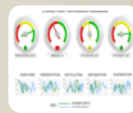

*Energy Info.*



*Electrical Load Mgt*

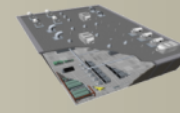

*HVAC -R*



*Central Utilities.*

## Services



*Energy Assessment*



*Asset Management*



*Training*

## Tools



*Energy Accelerator Toolkit*

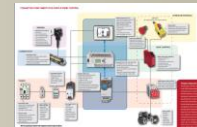

*CCBB Energy*



*Energy Savings Calc*

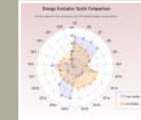

*Energy Evaluator*

# Common Problems Associated With Power



SAG

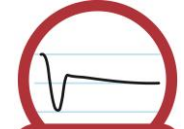

INTERRUPTION



NOISE



SURGE



UNDERVOLTAGE



OVERVOLTAGE

- Sag (Dip)
  - Variation below nominal RMS voltage of 10-90% with a duration ½ cycle to 1 minute
- Interruption (Outage)
  - Complete loss of line power
- Harmonics / Noise
  - Harmonics/Noise are non-useful voltages and currents that are the result of non-linear electric loads. Harmonics/Noise impact the waveform, creating complexity and non-uniformity to sinusoidal electrical circuits
- Surge (Transients)
  - Momentary non-uniform changes in voltage or current (less than 1 cycle)
- Over voltage
  - Steady state voltage event of more than 110% nominal for one minute or longer
- Under voltage
  - Steady state voltage event of less than 90% nominal for one minute or longer

# Rockwell Automation Power Quality

**Rockwell  
Automation**

## Power Quality Monitors



*I-Sense*



*PM 3000*



*PM 5000*

## Information

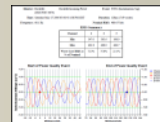

*I-Grid*

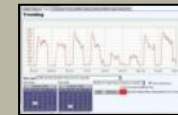

*FTEnergy Metrix*

## Interruption



*UPS Portfolio*

## Sag



*DySC Portfolio*

## Surge / Noise



*Surge*



*Filters*

# Energy Information Architecture

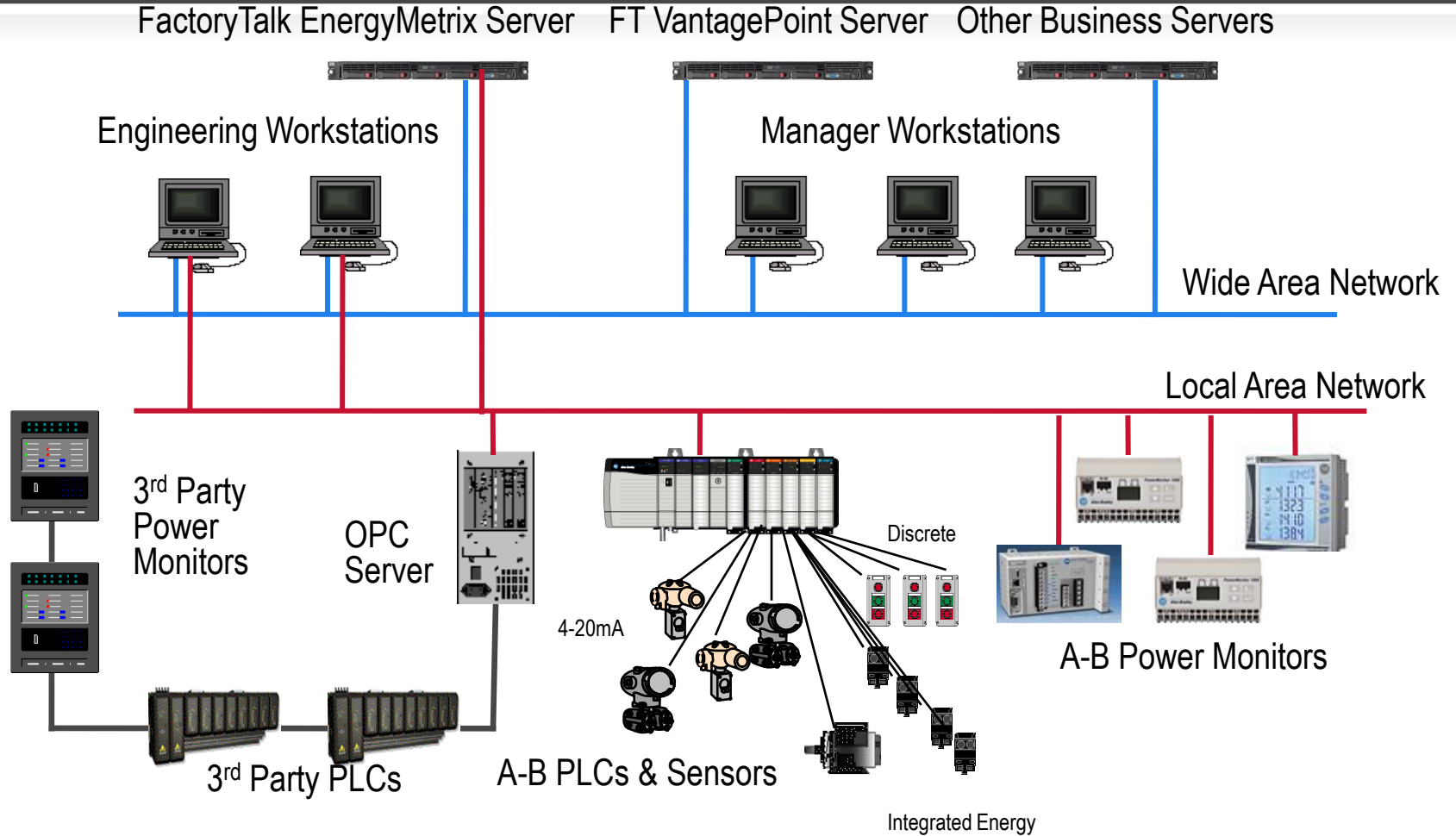

**WAGES - Water, Air, Gas, Electric and Steam**

# Start with Metering

- Typically a solution starts with energy meters:
  - At the main – for Power Quality/ shadow billing
  - At each switch gear / main branch – for sub metering
  - At each High Value asset – for more detailed billing

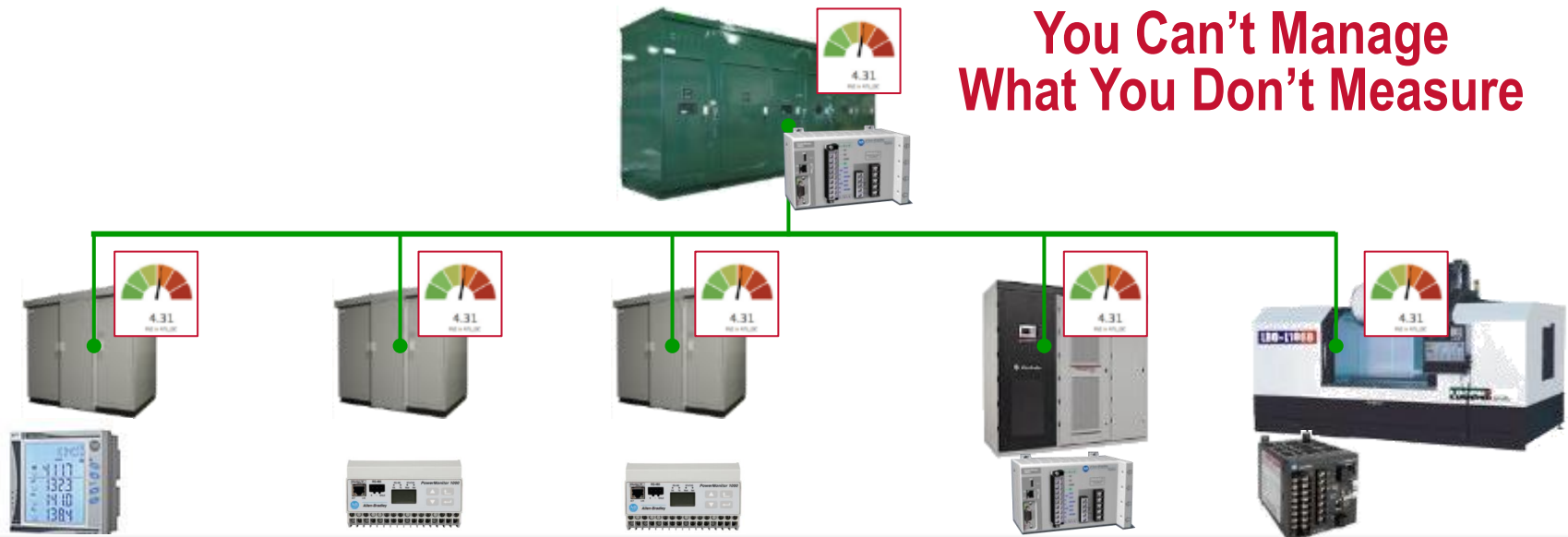

**You Can't Manage  
What You Don't Measure**



# Effective Energy Management

**You Can't Manage  
What You Don't Measure**

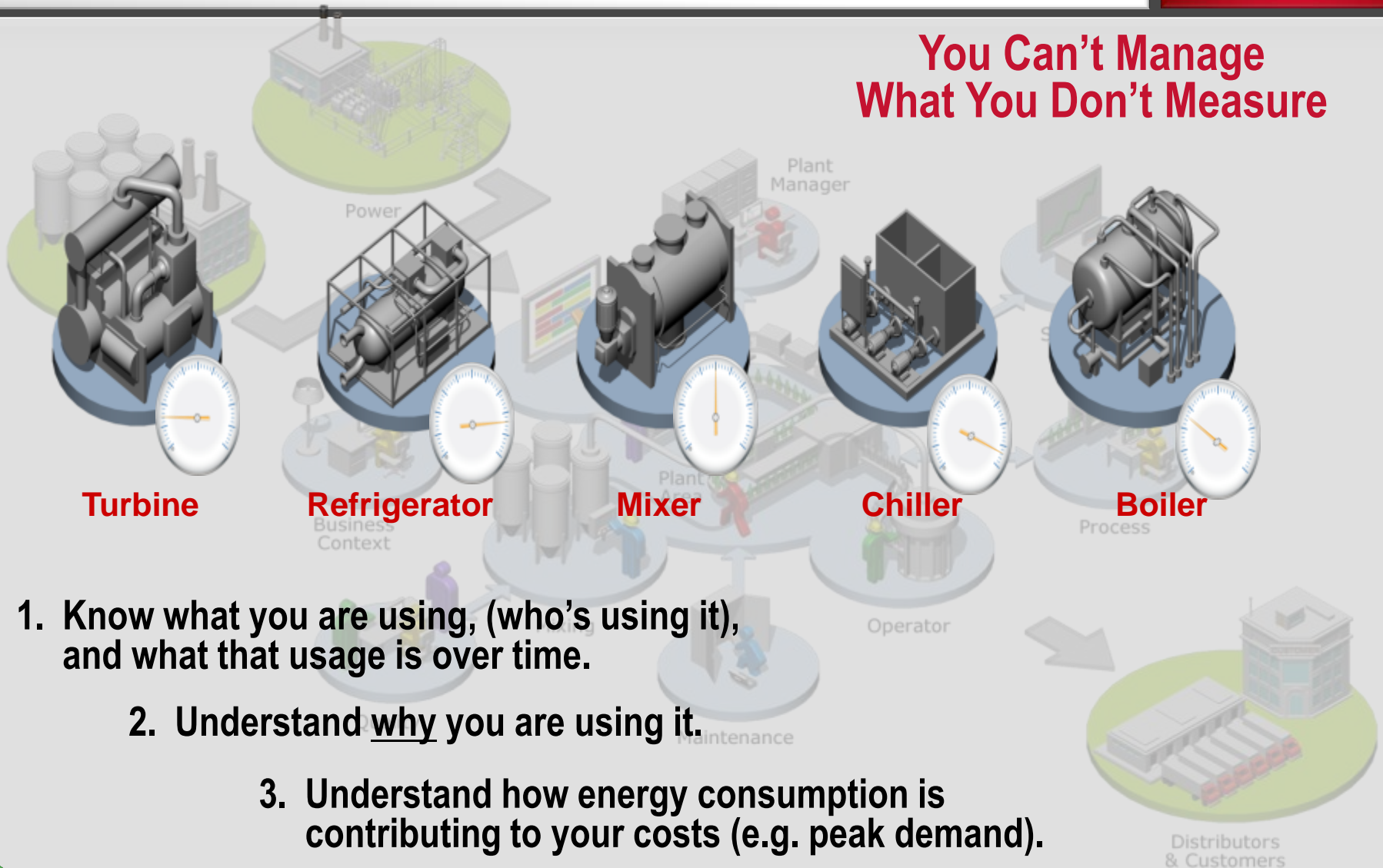

1. Know what you are using, (who's using it), and what that usage is over time.
2. Understand why you are using it.
3. Understand how energy consumption is contributing to your costs (e.g. peak demand).

# Agenda

Introduction to Energy Management

**PowerMonitors**

FT EnergyMetrix Demonstration

Summary and Q & A





# PowerMonitor 1000

PowerMonitor 1000 is a compact power monitor for load profiling, cost allocation or energy control.

## OUTPUTS:

- Modbus RTU
- EtherNet/IP
- KYZ Signal

## INPUTS:

- Digital signal

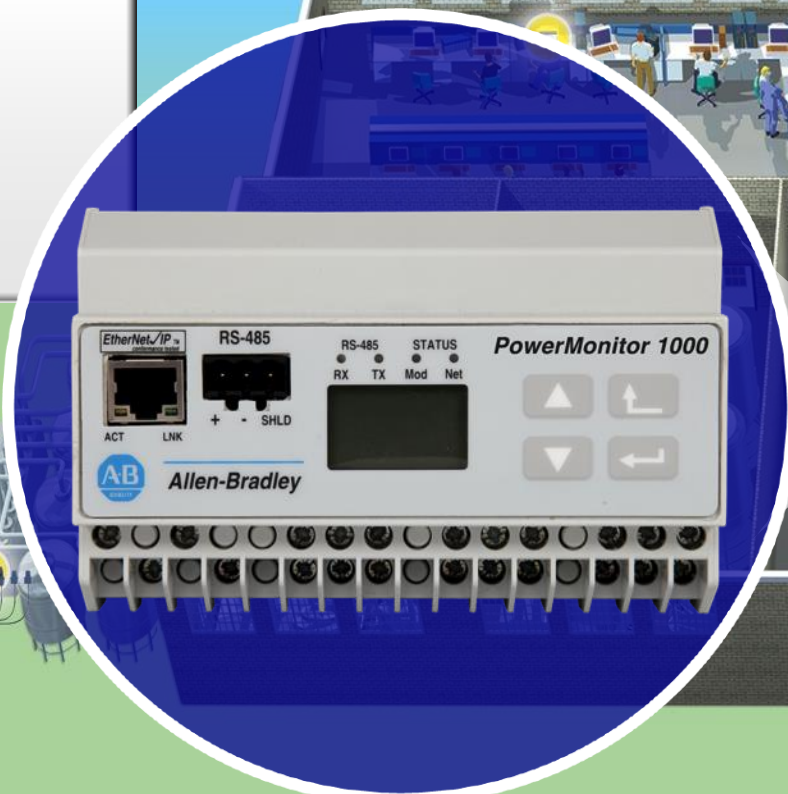

FACTORY FLOOR

# PowerMonitor™ 1000

## Metering

- Consumption (kWh)
- Demand (kW)\*
- Power Factor (%)\*

\* *Optional*

## Communication

- EtherNet/IP
- Serial



## Key Features

- Embedded web page for real-time data and configuration
- DIN-rail mounted
- Diagnostic utility for incorrect wiring
- Two status inputs for external metering (Water, Air, Gas, etc.)
- Integrated display for configuration

## *Sub-Process Meter*

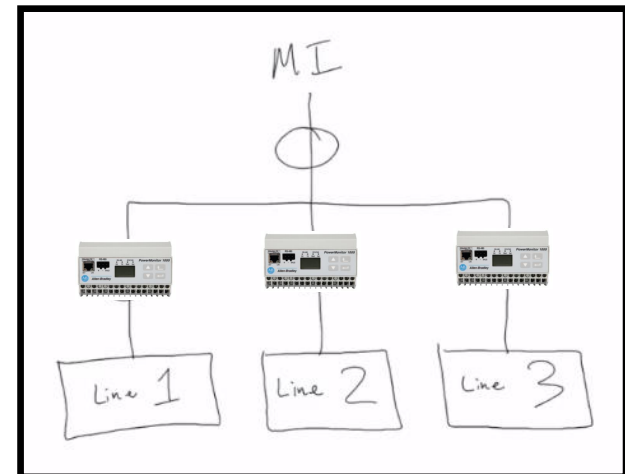

# PowerMonitor 500

PowerMonitor 500 is a cost-effective power monitor featuring an on-device LCD display in a compact footprint.

## OUTPUTS:

- Digital signal
- Analog signal
- Modbus RTU
- EtherNet/IP

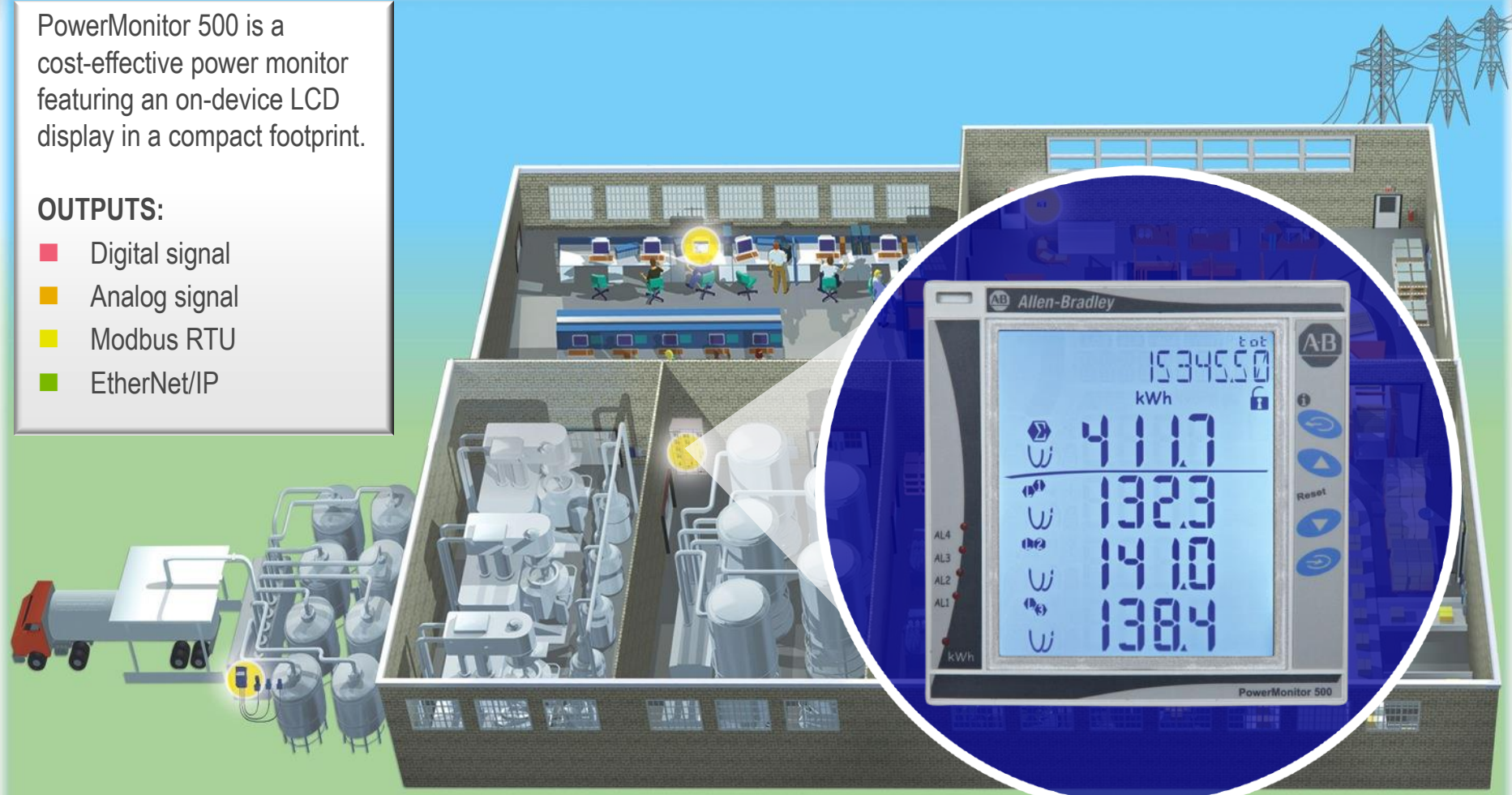

FACTORY FLOOR

# Allen-Bradley PowerMonitor 500

The PowerMonitor 500 features an on-device LCD display giving you instant visibility into your energy use.

## Greater Visibility

- Display and data communications allow you to record data centrally and display it locally
- Easy-to-configure on-device display simplifies installation
- Built in LCD display helps you make at-process decisions using real time data

## Compact Footprint

- Compact size and panel mounting saves space
- Fewer components and simplified wiring make it easy to install
- Optional digital or analog outputs

## Monitor and Reduce Energy Consumption

- Better understand where and when power is used
- Fully integrated with FTEnergyMetrix
- Instant accurate energy information can help lower operating costs



# PowerMonitor™ 500

## Metering

- Consumption (kWh)
- Demand (kW)
- Power Factor (%)

## Communication

- EtherNet/IP
- Serial



## Key Features

- Door mounted
- Large backlit display for real-time monitoring
- Fully configurable by touchkeys and display
- Configurable alarming
- Integration with FactoryTalk EnergyMetrix
- Integrated analog or digital outputs (optional)

## *At-Process Meter*

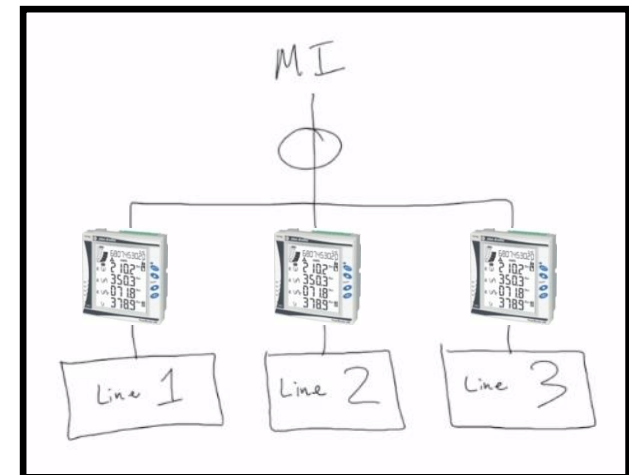

# Allen-Bradley PowerMonitor 5000

The PowerMonitor 5000 is the next generation of high-end, power quality metering product from Rockwell Automation. This PowerMonitor leverages new technology and capabilities to capture an exhaustive amount of data about your energy network.

## Product Highlights:

- Monitors 4 voltage and 4 current channels for every electrical cycle
  - 1024 data points across 8 channels every 12-17 milliseconds
- Measures up to the 127<sup>th</sup> Harmonic
  - Roughly 1,000 data points every cycle
- Calculates over 6,000 parameters every cycle
- Option for two communications ports
- 4 digital inputs for WAGES data collection
- 4 outputs for connection to SCADA or control systems
- Configurable alarms for up to 20 events
- Virtual Rewiring Capability
- **EtherNet/IP and/or DeviceNet communications**
- **Separate display (1426-DM) for displaying power and energy data for up to 3 PowerMonitor 5000s**



# Key Features

- Power and Energy Metering
  - Voltage
  - Current
  - Real, Reactive, and Apparent Energy
  - Demand
  - Power Factor
- Revenue Metering Accuracy (0.2%)
- Internal webpage for configuration and data review
- Flicker
- Waveform Capture
- Harmonic Analysis
- Sub-Cycle Transient detection
- Full metering update every cycle
- Virtual rewiring capability
- System event snapshot capability

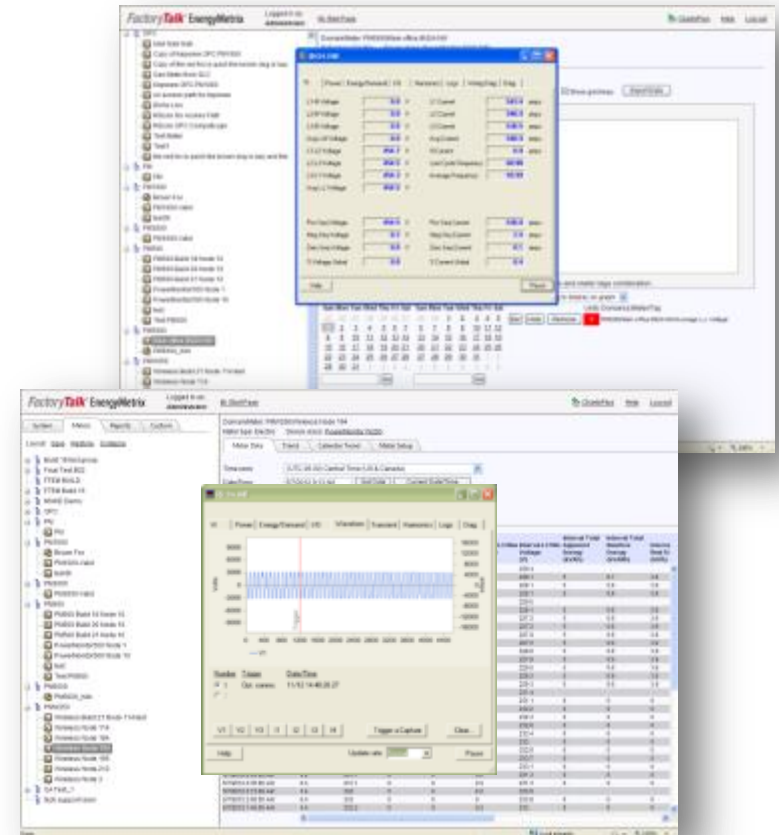

# Agenda

Introduction to Energy Management

E300 Overload Relay

FT EnergyMetrix Demonstration

Summary and Q & A





# E300 Electronic Overload Relay

*The E300 Electronic Overload Relay is the latest technology for motor protection that will help reduce your motor control investment and keep your plant running*

- Intelligent Motor Control
  - Native Ethernet/IP connectivity with easy commissioning, control, and monitoring.
- Scalable Solutions
  - Modularity in the design provides the right solution for your specific needs
- Real-time Information
  - Motor diagnostics to reduce unplanned downtime



# Intelligent Motor Control

## The E300 is fully integrated into the Integrated Architecture

- Network connectivity - *Native Ethernet/IP reduces hardware and engineering cost*
- Integrated into Logix – *Device profiles and faceplates reduce engineering time and project development*
- Automatic Device Configuration – *Reduces time to repair*

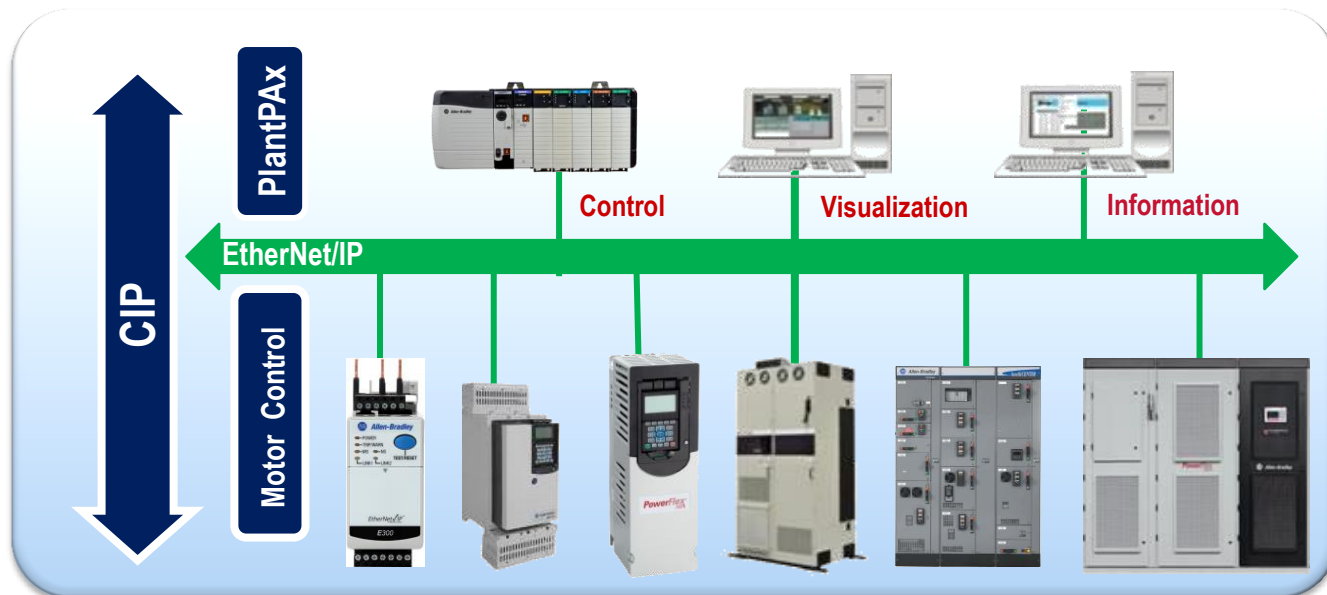

**Simultaneous real-time control, configuration, and data acquisition**

# Scalable Solutions

*The modular design allows users to have choices in each of the sensing, control, and communications modules with additional accessories to tailor the E300 overload for the application's exact needs:*

- Multiple Sensing Capabilities (*Current, Ground Fault Current, and Voltage & Power*)
- Simplified Control Wiring (*120V AC, 240V AC, and 24V DC*)
- Wide Current Range (*10:1 and Higher*)
- Expansion I/O (*Digital & Analog I/O*)
- Operator Interfaces
- Stocked Modules for Fast Replacement



# Motor Diagnostics

- The E300 provides a wide variety of diagnostic information to monitor motor performance and proactively alert users to possible motor issues
- This information can trigger either manual or automatic intervention before the occurrence of an unplanned shutdown
  - Voltage, Current, & Energy
  - CIP Energy Enabled
  - Trip / Warning Histories
  - % Thermal Capacity Utilization
  - **Motor Winding Temperature**
  - Trip Snap Shot
  - Time to Trip
  - Time to Reset
  - Operational Hours
  - Number of Starts

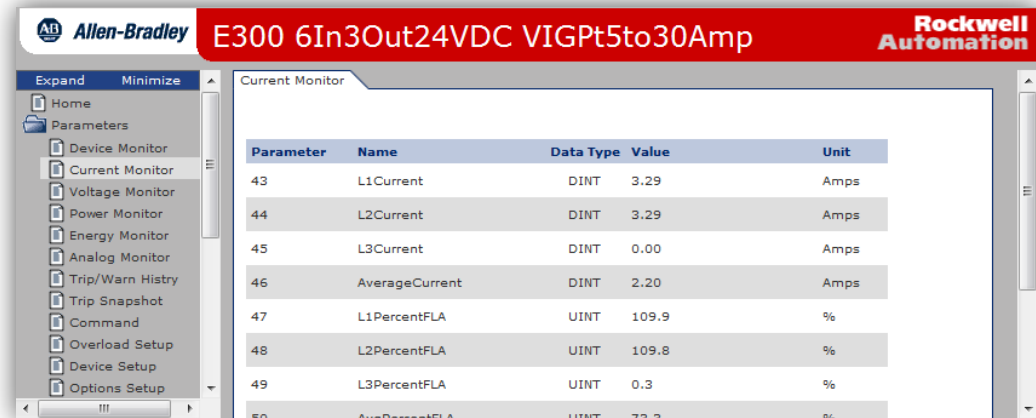

The screenshot displays the Allen-Bradley E300 6In3Out24VDC VIGPt5to30Amp Rockwell Automation interface. The main window is titled "Current Monitor" and contains a table with the following data:

Parameter	Name	Data Type	Value	Unit
43	L1Current	DINT	3.29	Amps
44	L2Current	DINT	3.29	Amps
45	L3Current	DINT	0.00	Amps
46	AverageCurrent	DINT	2.20	Amps
47	L1PercentFLA	UINT	109.9	%
48	L2PercentFLA	UINT	109.8	%
49	L3PercentFLA	UINT	0.3	%
50	AvgPercentFLA	UINT	73.3	%

# Reduced Wiring and Installation Costs



E300 Overload Relay modules easily snap together and are secured with tabs.

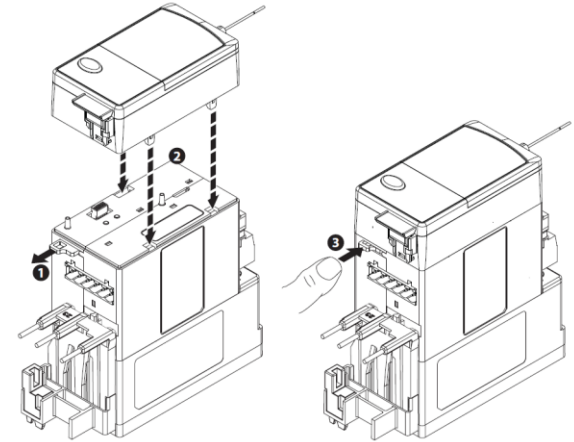

Simplified wiring between E300 Overload Relay and 100-C Contactor

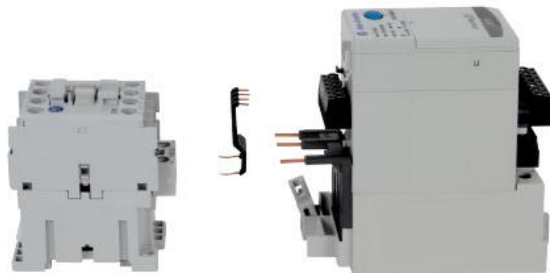

Operating Stations feature a 22mm push button cutout



# Flexibility and Functionality

*The E300 can be applied to three styles of motor starters*

- Panel / DIN Rail
- 100-C IEC Contactors
- 300/500 NEMA Contactors



# Agenda

Introduction to Energy Management

**FactoryTalk EnergyMetrix**

FT EnergyMetrix Demonstration

Summary and Q & A



# Energy Intelligence Products

Under the umbrella of **Energy Intelligence**, we have the following offerings:

- **FactoryTalk VantagePoint Energy**
  - EnergyMetrix Connector, Model components and Report content
  - Extend an existing FactoryTalk VantagePoint solution
  - or purchase as a bundle with VantagePoint EMI
- **FactoryTalk EnergyMetrix**
  - A complete power quality and analysis tool
  - Billing and energy cost allocation capabilities
- **IntelliCENTER Energy**
  - Preconfigured setup of FactoryTalk EnergyMetrix as part of an intelligent motor control solution





# Energy Intelligence Product Overview

## FactoryTalk VantagePoint EMI

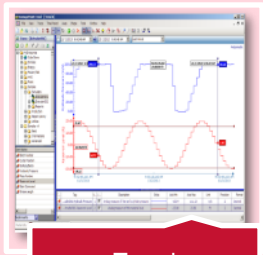

Trend



Excel Reports



Dashboard



Customized examples

## FactoryTalk VantagePoint Energy Add-on

Energy Organization Level Types

Energy Equipment Types

Energy Meter Types

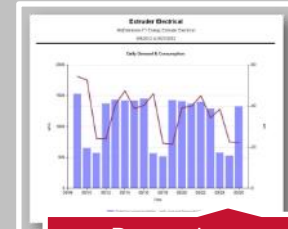

Demand vs. consumption charts



48hr dashboard

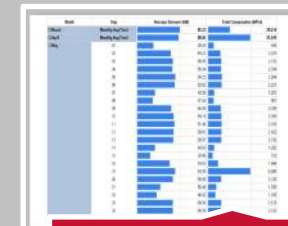

Tabular reports

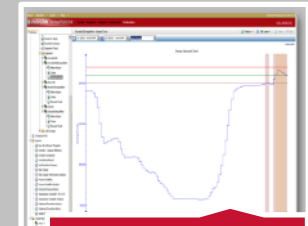

Demand charts

## FactoryTalk EnergyMatrix



Real time access to Power Meters



Demand and consumption reporting

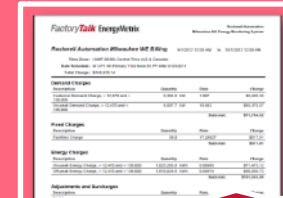

Advanced billing capabilities



Power Quality reporting and analyses



# FactoryTalk VantagePoint Energy

## Energy information for making intelligent decisions

**Rockwell  
Automation**

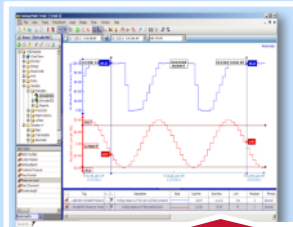

Trend



Excel Reports



Demand vs.  
consumption charts



48hr dashboard



Demand charts



Dashboard



Date	Qty	Amount	Unit
01/01/10	100	1000	USD
01/02/10	200	2000	USD
01/03/10	300	3000	USD
01/04/10	400	4000	USD
01/05/10	500	5000	USD
01/06/10	600	6000	USD
01/07/10	700	7000	USD
01/08/10	800	8000	USD
01/09/10	900	9000	USD
01/10/10	1000	10000	USD

Tabular reports



Customized examples

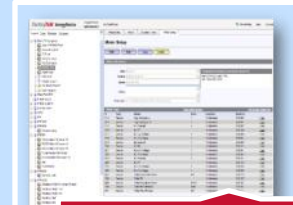

Real time access to  
Power Meters



Demand and  
consumption reporting



Advanced billing  
capabilities

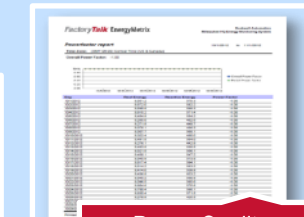

Power Quality  
reporting and analyses

# Energy Consumption / Power Quality

## FactoryTalk® EnergyMetrix

Scalable, web-based energy management software that captures, analyzes, stores, and shares energy data across the entire enterprise for informed energy decisions

- Optimize energy procurement
- Accurate cost accounting for energy usage
- Drive intelligent decisions around electrical capacity
- Integration with all Allen-Bradley hardware  
(PMW250, PM500, PM1000, PM5000, VFDs, E300)
- Visualization tools and reports for process, department, facility, or enterprise reporting
  - Load profiling, cost allocations, tariff analysis, billing, etc.

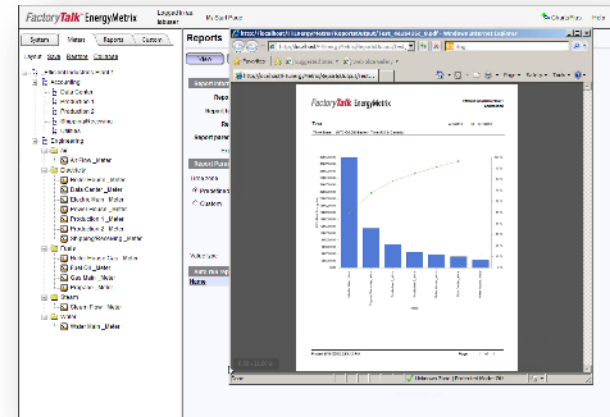

***Meter data is important for any Energy Management system!  
EnergyMetrix is a source of meter data for Energy Intelligence.***

# Meter Data Management

Centrally manage Power Meters throughout the Plant

Rockwell  
Automation

- **Configure Meters**

- Connect to Rockwell Automation Power Meters and configure meters and meter tags

- **Collect Meter data**

- Collect and store meter data from Rockwell and 3<sup>rd</sup> party meters in Database
- Trend meter data

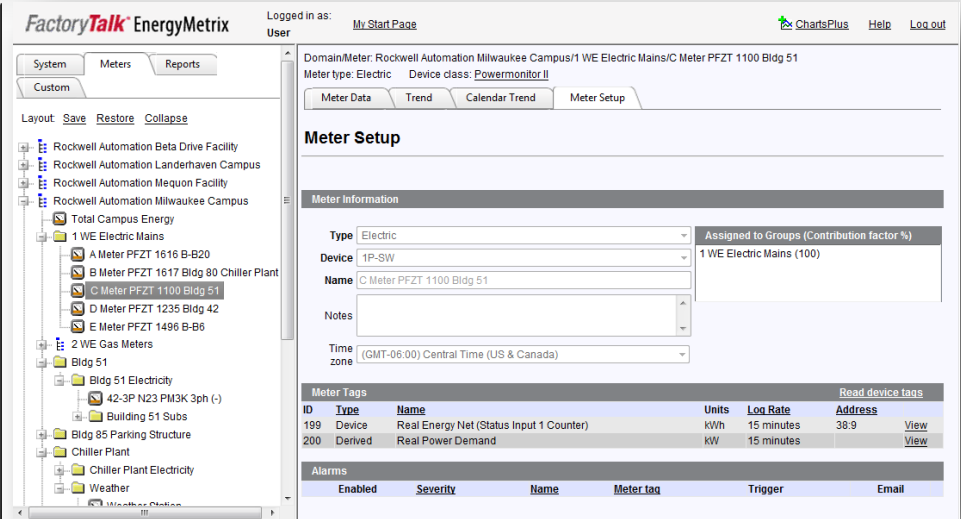

The screenshot shows the 'Meter Setup' page in the FactoryTalk EnergyMetrix application. The left sidebar displays a tree view of the plant hierarchy, with 'C Meter PFZT 1100 Bldg 51' selected. The main area contains the 'Meter Setup' form, which includes fields for 'Type' (Electric), 'Device' (1P-SW), 'Name' (C Meter PFZT 1100 Bldg 51), and 'Assigned to Groups' (1 WE Electric Mains (100)). Below the form is a table of 'Meter Tags' with columns for ID, Type, Name, Units, Log Rate, and Address. The table lists two tags: '199 Device Real Energy Net (Status Input 1 Counter)' and '200 Derived Real Power Demand'. An 'Alarms' table is also visible at the bottom.

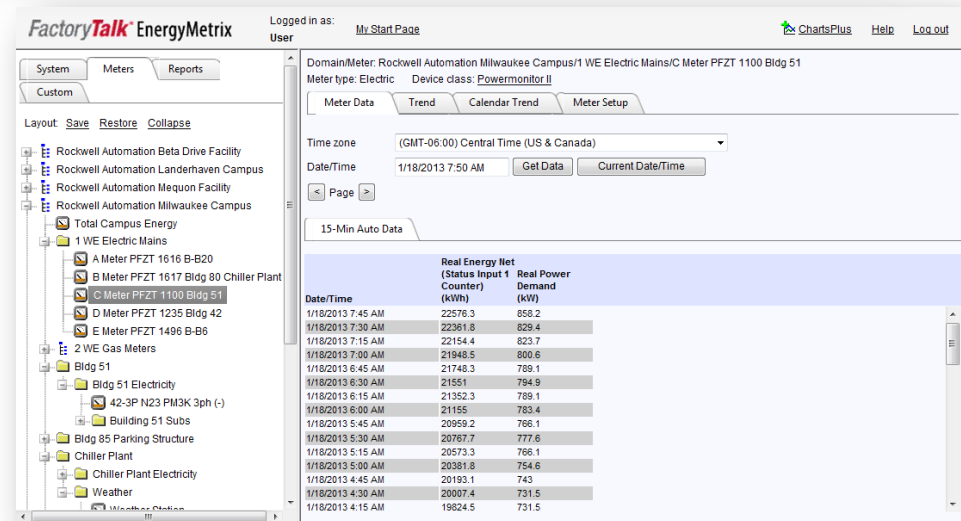

The screenshot shows the 'Trending' page in the FactoryTalk EnergyMetrix application. The left sidebar is the same as in the previous screenshot. The main area displays a table of 'Real Energy Net (Status Input 1 Counter)' and 'Real Power Demand (kW)' data. The table has columns for Date/Time, Real Energy Net (kWh), and Real Power Demand (kW). The data is filtered for the date 1/18/2013 and shows values for various times throughout the day.

Date/Time	Real Energy Net (kWh)	Real Power Demand (kW)
1/18/2013 7:45 AM	22576.3	858.2
1/18/2013 7:30 AM	22361.8	829.4
1/18/2013 7:15 AM	22154.4	823.7
1/18/2013 7:00 AM	21948.5	800.6
1/18/2013 6:45 AM	21748.3	789.1
1/18/2013 6:30 AM	21551	784.9
1/18/2013 6:15 AM	21352.3	789.1
1/18/2013 6:00 AM	21155	783.4
1/18/2013 5:45 AM	20959.2	766.1
1/18/2013 5:30 AM	20767.7	777.6
1/18/2013 5:15 AM	20573.3	766.1
1/18/2013 5:00 AM	20381.8	754.6
1/18/2013 4:45 AM	20193.1	743
1/18/2013 4:30 AM	20007.4	731.6
1/18/2013 4:15 AM	19824.5	731.5

# Advanced Trending of Power Data

Traditional trend and advanced “Calendar Trend”

**Rockwell  
Automation**

- Trending Energy
  - Trending Power and Consumption data over time
- Calendar Trend
  - Powerful tool to compare Power and Demand day to day, week to week etc.

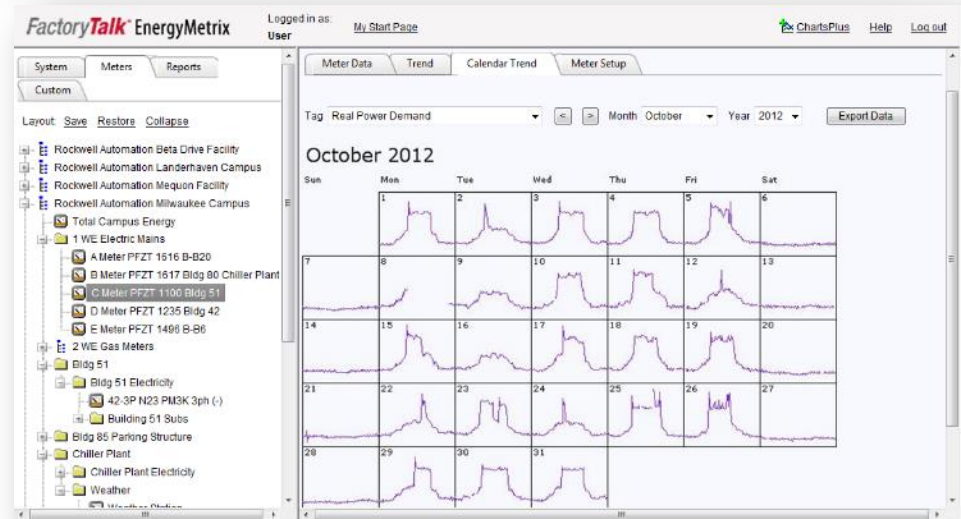
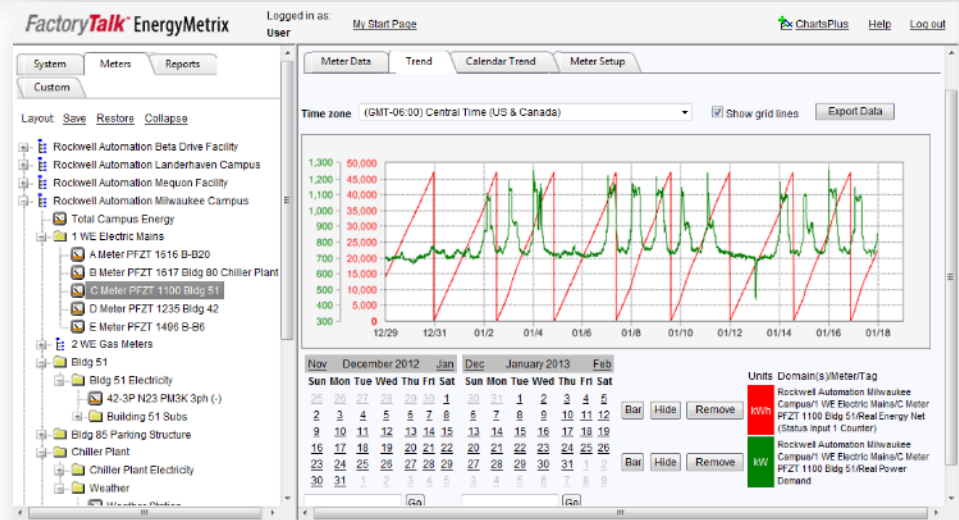

# Additional Charting Capabilities

Shared Charts improve collaboration and save valuable time

## ■ Pareto Charts

- Plots Energy data from various meters of your choice on a Pareto chart

## ■ Enhanced and Custom Charts

- Enhanced Charts package
- Load Factor Charts
- Custom Charts
- X-Y Trending
- Targeting and COSUM analysis

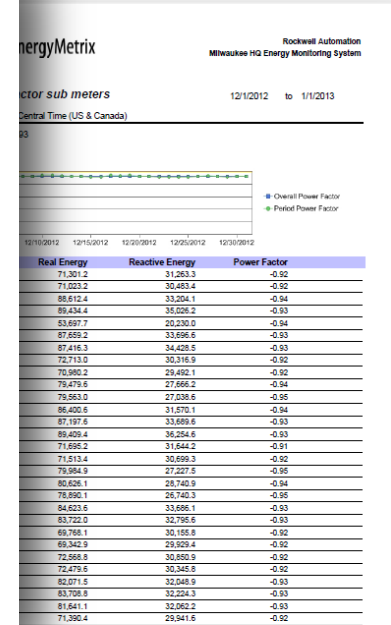
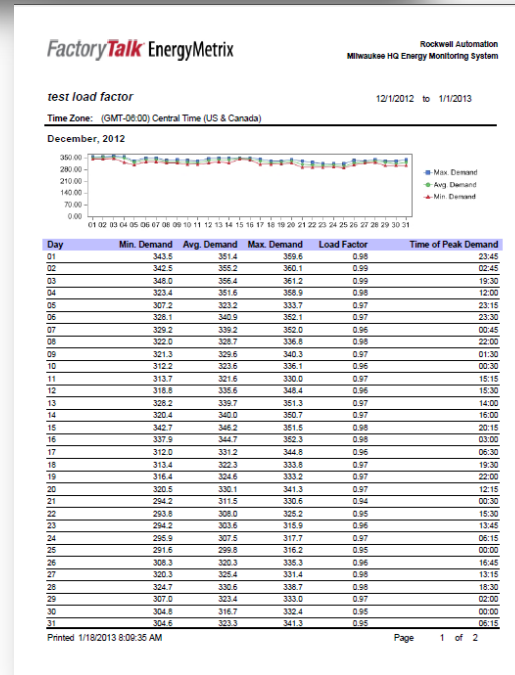
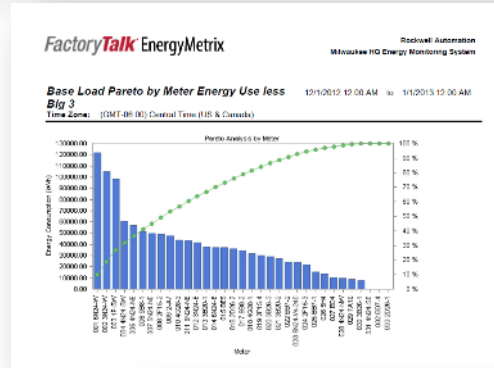

# Flexible Reporting

## Reporting Tool and Excel Add-on

- Reports Templates

- Comparative Billing
- Billing Roll-up
- Efficiency
- Trend

- Custom Reports

- Customizable Reporting
  - Excel Template
  - Excel Add-on
  - Visual Basic scripting

The image displays several screenshots of the FactoryTalk EnergyMetrix reporting tool. The top left shows a web browser window displaying a 'FactoryTalk EnergyMetrix' report for 'Billing UK' from 01/04/2012 00:00 to 01/05/2012. The report includes a table for 'energy charge' with columns for Description, Quantity, and Rate. A pie chart titled 'Monthly Utility (Energy) Usage In' is also visible. The top right shows another report for 'Monthly Utility (Energy) Cost Allocation' with a pie chart and a line graph showing trends over time. The bottom section shows an Excel spreadsheet with the 'FactoryTalk EnergyMetrix' add-on. The spreadsheet has columns for Regapor Name, Start Date, End Date, and Timezone. Below this is a bar chart titled 'Electric Main \_ Meter' showing energy usage in kwh over time. The bottom of the Excel spreadsheet shows a table with columns for Date and Energy (kwh).

# Demand and Consumption Reporting

Shared Reports improve collaboration and save valuable time

- Consumption Report

- Shows consumption values (kWh, kVARh, etc) for selected meters/groups for the specified time range

- Demand Analysis Report

- Shows Demand values (kW) for selected meters/groups for the specified time range
- Shows Peak Demand Usage

FactoryTalk EnergyMetrix Rockwell Automation  
Milwaukee HQ Energy Monitoring System

**Demand analysis** 9/1/2012 12:00 AM to 10/1/2012 12:00 AM

Time Zone: (GMT-08:00) Central Time (US & Canada)

**kW**

**Peak Demand Summary**

Meter	Demand (kW)	%	Time
A Meter PFZT 1616 B-620	748.8	12.5%	9/4/2012 11:15:00 AM
E Meter PFZT 1496 B-60	625.9	10.4%	9/4/2012 11:15:00 AM
D Meter PFZT 1235 Bldg 42	1,756.8	29.2%	9/4/2012 11:15:00 AM
C Meter PFZT 1100 Bldg 51	1,071.4	17.8%	9/4/2012 11:15:00 AM
B Meter PFZT 1617 Bldg 80 Chiller Plant	1,804.8	30.0%	9/4/2012 11:15:00 AM
<b>Total</b>	<b>6,097.7</b>	<b>100.0%</b>	

**Worst Case Peak Demand Analysis**

Meter	Demand (kW)	%
A Meter PFZT 1616 B-620	783.4	11.9%
E Meter PFZT 1496 B-60	645.1	9.8%
D Meter PFZT 1235 Bldg 42	1,756.8	26.0%
C Meter PFZT 1100 Bldg 51	1,255.7	19.0%
B Meter PFZT 1617 Bldg 80 Chiller Plant	2,154.2	32.7%
<b>Total</b>	<b>6,595.2</b>	<b>100.0%</b>

Printed 10/18/2012 9:27:59 AM

FactoryTalk EnergyMetrix Rockwell Automation  
Milwaukee HQ Energy Monitoring System

**Consumption** 9/1/2012 12:00 AM to 10/1/2012 12:00 AM

Time Zone: (GMT-08:00) Central Time (US & Canada)

**Steam**

Item	Steam Usage (mb)
WE Steam Meter	3,464
<b>Total(s):</b>	<b>3,464</b>

**Parking Structure Electricity**

Item	Real Energy Net (kWh)
Building 85	9,277
<b>Total(s):</b>	<b>9,277</b>

**Data Center**

Item	Real Energy Net (kWh)	Reactive Energy Net (kVARh)
4N24-SE PMSK	29	1
5N24-SE PMSK	259,473	17,351
6N23-E New	201,927	92,481
8N24-SW New	14,984	11,917
<b>Total(s):</b>	<b>556,412</b>	<b>121,750</b>

Printed 10/18/2012 9:25:40 AM Page 1 of 1



# Advanced Billing Capabilities

Shadow billing as well as department / tenant billing

**Rockwell  
Automation**

## ■ Billing Report

- Provides billing information for the selected meters/groups for the specified time range
- Provides line items and a total charge amount.

## ■ Cost Allocation Report

- Shows cost per specified area based on actual usage

FactoryTalk EnergyMetrix

Rockwell Automation  
Milwaukee HQ Energy Monitoring System

Rockwell Automation Milwaukee WE Billing 9/1/2012 12:00 AM to 10/1/2012 12:00 AM

Time Zone: (GMT-06:00) Central Time (US & Canada)

Rate Schedule: W CP1 WI Primary TOU fixed 85 PF After 01012011

Total Charge: \$240,920.14

### Demand Charges

Description	Quantity	Rate	Charge
Customer Demand Charge, > 12,470 and < 138,000	6,364.8 kW	1.007	\$6,409.35
On-peak Demand Charge, > 12,470 and < 138,000	6,007.7 kW	10.882	\$65,375.57
Subtotal:			\$71,784.92

### Fixed Charges

Description	Quantity	Rate	Charge
Facilities Charge	30.0	17.26027	\$517.81
Subtotal:			\$517.81

### Energy Charges

Description	Quantity	Rate	Charge
On-peak Energy Charge, > 12,470 and < 138,000	1,023,265.8 kWh	0.06985	\$71,475.12
Off-peak Energy Charge, > 12,470 and < 138,000	1,810,026.6 kWh	0.04974	\$90,030.72
Subtotal:			\$161,505.84

### Adjustments and Surcharges

Description	Quantity	Rate	Charge
Fuel Cost Adjustment, On Peak	1,023,265.8 kWh	0.00251	\$2,568.40
Fuel Cost Adjustment, Off Peak	1,810,026.6 kWh	0.00251	\$4,543.17
Subtotal:			\$7,111.57

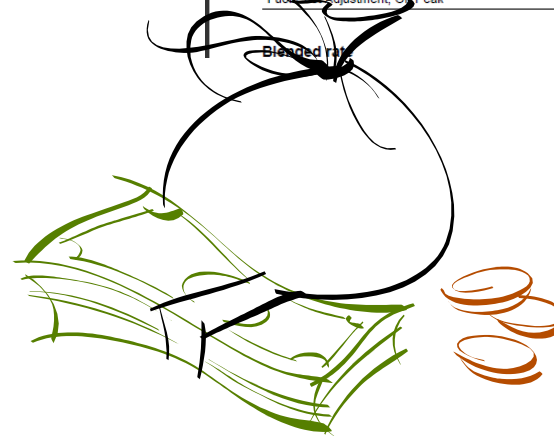

# Power Quality Reporting and Analysis

When system is connected to AB Power monitors

- Power Quality Report

- Shows sag/swell information detected by AB PowerMonitor products
- Display waveforms and harmonics in graphical or log formats

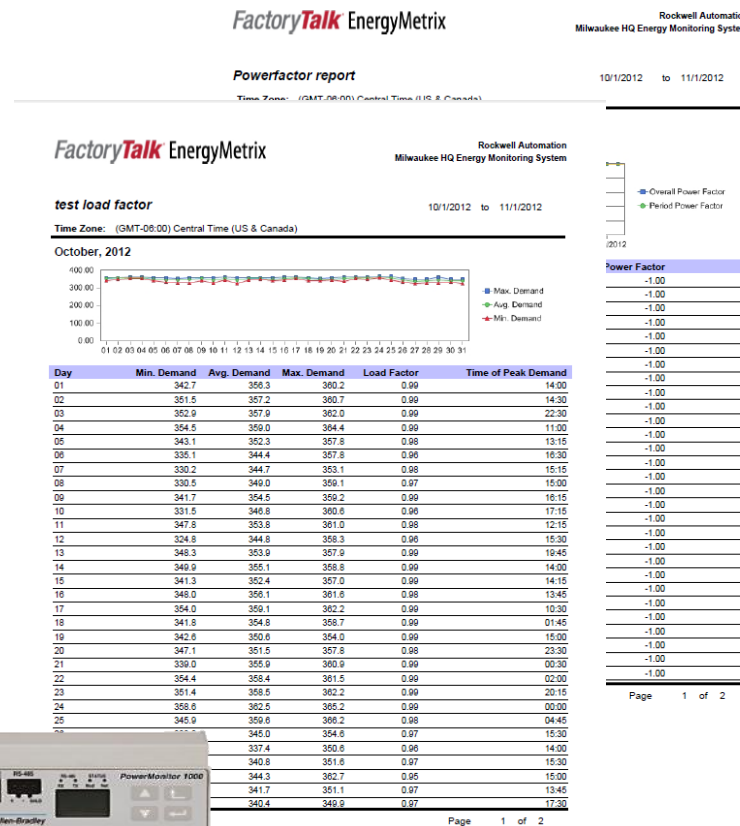

# Real-time Access to Power Monitors

When system is connected to AB Power monitors



- Configure and view Allen-Bradley power monitors
- View meter data including real-time and historical (stored within the monitors)
- Display waveforms and harmonics in graphical or log formats

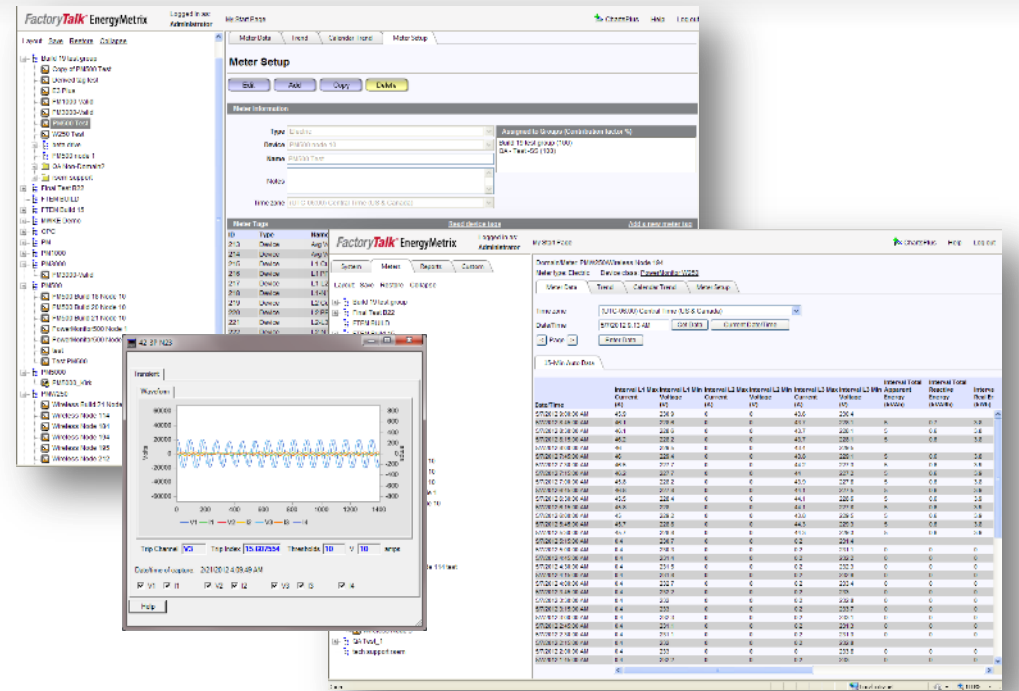

# Demo?

**Rockwell  
Automation**



# Questions?

**Rockwell  
Automation**



For more information:

**Rockwell  
Automation**

Discover

<http://discover.rockwellautomation.com/energy>



**Download the Energy Intelligence e-Book**



- Training is available for the FactoryTalk Products through Rockwell Automation's training site at:
  - <http://www.rockwellautomation.com/services/training/schedules.html>

The screenshot shows the Rockwell Automation website's Training Services page. The header includes the Rockwell Automation logo, a location selector set to "United States" with a "+ Worldwide" dropdown, and a "Go" button. A navigation bar contains links for "About Us", "News & Events", "Products", "Services & Support", and "Industries & Solutions". The left sidebar lists "Training Services" with sub-links: Overview, Self-Paced Training (Computer-based, Web-based, Job Aids, Training Workstations), Instructor-led Training (Standard, Onsite, Tailored), ControlLogix Certificate Program, Assessment Services, Savings Program, Literature, and Case Studies. The main content area is titled "TRAINING SERVICES Software Courses Curriculum" and features "Instructor-Led Training" with a list of 10 courses, each with a link and duration. At the bottom, there are links for "Tools & Resources", "Locations", "Contact Us", "Sitemap", and "Legal Notices", followed by the copyright notice: "Copyright © 2009 Rockwell Automation, Inc. All Rights Reserved."

**Rockwell Automation** United States

[About Us](#) [News & Events](#) [Products](#) [Services & Support](#) [Industries & Solutions](#)

**Training Services**

- Overview
- > Self-Paced Training
  - Computer-based Training
  - Web-based Training
  - Job Aids
  - Training Workstations
- > Instructor-led Training
  - Standard Training
  - Onsite Training
  - Tailored Training
- ControlLogix Certificate Program
- Assessment Services
- + Savings Program
- Literature
- Case Studies

## TRAINING SERVICES

### Software Courses Curriculum

#### Instructor-Led Training

- [Microsoft SQL Server for FactoryTalk Introduction](#) [RS-MSSQLB, 2 Days]
- [RSMACC Installation and Configuration](#) [RS-RSMACC, 3 Days]
- [RSTestStand Enterprise Project Development](#) [RS-RSTS101-LD, 2 Days]
- [FactoryTalk AssetCentre Configuration](#) [RS-FTACC, 2 Days]
- [FactoryTalk Historian Site Edition Configuration and Data Collection](#) [RS-FTHSEC, 3.5 Days]
- [FactoryTalk Historian Site Edition Data Analyzing and Reporting](#) [RS-FTHSEDA, 3.5 Days]
- [FactoryTalk Metrics with Historian Classic Configuration](#) [RS-FTMHCC, 4 Days]
- [FactoryTalk Transaction Manager](#) [RS-FTTM, 3 Days]
- [FactoryTalk VantagePoint Configuration](#) [RS-FTVP, 3 Days]
- [FactoryTalk VantagePoint EMI Configuration and Reporting](#) [RS-FTVPEMI, 4 Days]
- [Power Monitor Installation and RSEnergyMetrix Software Configuration in an Energy Monitoring System](#) [RS-EMPM, 2 1/2 Days]

[Tools & Resources](#) | [Locations](#) | [Contact Us](#) | [Sitemap](#) | [Legal Notices](#)  
Copyright © 2009 Rockwell Automation, Inc. All Rights Reserved.

# Energy Management Accelerator Toolkit

- Modeled after other RA Integrated Architecture Accelerator Toolkits
- <http://www.rockwellautomation.com/go/iatools>
- CD IASIMP-SP014
- Contains:
  - Step by Step Quick Start Guide
  - System Design and Configuration
  - Hardware Selection Tools
  - CAD Layout and Wiring Drawings
  - Simplified Device Configuration
  - Preconfigured Logic
  - Preconfigured Faceplates
  - System Operation Guide

## Energy Management Accelerator Toolkit





LISTEN.  
THINK.  
SOLVE.®

# Thank You!



PUBLIC INFORMATION



Follow ROKAutomation on Facebook & Twitter.  
Connect with us on LinkedIn.

[www.rockwellautomation.com](http://www.rockwellautomation.com)

 Allen-Bradley • Rockwell Software

**Rockwell  
Automation**