

Kinetix 2000 Multi-axis Servo Drives to Kinetix 5500 Servo Drives



Important User Information

Read this document and the documents listed in the additional resources section about installation, configuration, and operation of this equipment before you install, configure, operate, or maintain this product. Users are required to familiarize themselves with installation and wiring instructions in addition to requirements of all applicable codes, laws, and standards.

Activities including installation, adjustments, putting into service, use, assembly, disassembly, and maintenance are required to be carried out by suitably trained personnel in accordance with applicable code of practice.

If this equipment is used in a manner not specified by the manufacturer, the protection provided by the equipment may be impaired.

In no event will Rockwell Automation, Inc. be responsible or liable for indirect or consequential damages resulting from the use or application of this equipment.

The examples and diagrams in this manual are included solely for illustrative purposes. Because of the many variables and requirements associated with any particular installation, Rockwell Automation, Inc. cannot assume responsibility or liability for actual use based on the examples and diagrams.

No patent liability is assumed by Rockwell Automation, Inc. with respect to use of information, circuits, equipment, or software described in this manual.

Reproduction of the contents of this manual, in whole or in part, without written permission of Rockwell Automation, Inc., is prohibited.

Throughout this manual, when necessary, we use notes to make you aware of safety considerations.



WARNING: Identifies information about practices or circumstances that can cause an explosion in a hazardous environment, which may lead to personal injury or death, property damage, or economic loss.



ATTENTION: Identifies information about practices or circumstances that can lead to personal injury or death, property damage, or economic loss. Attentions help you identify a hazard, avoid a hazard, and recognize the consequence.

IMPORTANT

Identifies information that is critical for successful application and understanding of the product.

Labels may also be on or inside the equipment to provide specific precautions.



SHOCK HAZARD: Labels may be on or inside the equipment, for example, a drive or motor, to alert people that dangerous voltage may be present.



BURN HAZARD: Labels may be on or inside the equipment, for example, a drive or motor, to alert people that surfaces may reach dangerous temperatures.



ARC FLASH HAZARD: Labels may be on or inside the equipment, for example, a motor control center, to alert people to potential Arc Flash. Arc Flash will cause severe injury or death. Wear proper Personal Protective Equipment (PPE). Follow ALL Regulatory requirements for safe work practices and for Personal Protective Equipment (PPE).

Preface	Overview	7
	Kinetix 5500 Servo Drives	8
	Kinetix 5500 Servo Drive Features	8
	Kinetix 5500 Servo Drive Components	9
	Kinetix 5500 Servo Drive Selection	9
	Pre-migration	10
	Additional Resources	10
	 Chapter 1	
Servo Drive and System Considerations	Engineering Effort and Product Liability	13
	Communications	13
	Controller, Ethernet Cards, and Switches	14
	Motors	14
	Cable Lengths	15
	Physical Dimensions	15
	Control Power	15
	Circuit Protection	15
	Control Signals	16
	Safe Torque-off Safety Features	16
	Accessories	16
	 Chapter 2	
Servo Drive and System Comparisons	Drive Sizing	18
	Output Current Comparison	18
	Dimension Comparison	19
	Dimension Drawings	20
	Kinetix 2000 Servo Drive Dimensions – Integrated Axis Module	20
	Kinetix 2000 Servo Drive Dimensions – Axis Module	20
	Kinetix 5500 Servo Drive Dimensions	21
	AC Input Power Wiring and Fusing	22
	AC Input Power Wiring	22
	Circuit Breaker and Fuse Considerations	28
	Drive Interconnects and Cabling	32
	Motor Power and Feedback	32
	Kinetix 2000 Servo Drives with MP-Series Low Inertia Motors	32
	2090-Series Single Motor Cable Overview	33
	Kinetix 5500 (200V-class operation) Servo Drives with Kinetix VP Low Inertia Motors	33
	Kinetix 5500 (400V-class operation) Servo Drives with Kinetix VP Low Inertia Motors	34
	Kinetix 5500 Servo Drive Hiperface-to-DSL Feedback Converter Kit	35
	Digital Inputs	36
	Kinetix 2000 Servo Drive Digital Inputs	36
	Kinetix 5500 Servo Drive Digital Inputs	37

	Typical System Layout	38
	Kinetix 2000 Servo System Example	38
	Kinetix 5500 Servo Drive System Example	39
	Accessories	40
	Kinetix 2000 Servo Drive Accessories	40
	Kinetix 5500 Servo Drive Accessories	41
	Appendix A	
Connectors and Field Connections	Connector Locations	43
	Kinetix 2000 Servo Drive Connector Data	43
	Kinetix 5500 Servo Drive Connector Data	45
	Input Power Connector Pinouts	46
	Motor Power and Brake Pinouts	47
	Encoder Connector Pinouts	48
	I/O Connector Pinouts	49
	Appendix B	
About the Servo Drive System	About the Kinetix 2000 Servo Drive System	51
	About the Kinetix 5500 Servo Drive System	52
	Appendix C	
Specifications	Power Specifications	53
	Kinetix 2000 Servo Drive Converter Power Specifications	53
	Kinetix 2000 Servo Drive Inverter Power Specifications	54
	Kinetix 5500 Servo Drive Input Power Specifications	55
	Kinetix 5500 Servo Drive Output Power Specifications	56
	Control Power Specifications	57
	Kinetix 2000 Servo Drive Control Power Specifications	57
	Kinetix 5500 Servo Drive Control Power Specifications	57
	Power Dissipation Specifications	58
	Kinetix 2000 Servo Drive Power Dissipation Specifications	58
	Kinetix 5500 Servo Drive Power Dissipation Specifications	58
	Cable Lengths	59
	Kinetix 2000 Servo Drive Feedback Cable Lengths	59
	Kinetix 5500 Servo Drive Single Motor Cable Lengths	59
	Environmental Specifications	60
	Kinetix 2000 Servo Drive Environmental Specifications	60
	Kinetix 5500 Servo Drive Environmental Specifications	60
	Certifications	61
	Kinetix 2000 Servo Drive Certifications	61
	Kinetix 5500 Servo Drive Certifications	61

	Appendix D	
Interconnect Diagrams	Kinetix 2000 Servo Drive Examples.....	63
	Power Wiring Examples.....	63
	DC Common Bus Wiring Examples	66
	Kinetix 5500 Servo Drive Power Wiring Examples.....	67
	Single-axis Drive Wiring Examples.....	67
	Bus-sharing Wiring Examples	69
	Appendix E	
Communication Configurations	Kinetix 5500 Servo Drive Linear Topology.....	72
	Kinetix 5500 Servo Drive Ring Topology	73
	Kinetix 5500 Servo Drive Star Topology	74

Overview

The purpose of this migration guide is to provide you with the essential information to determine what hardware design changes may be necessary when migrating from a motion system containing Kinetix® 2000 servo drives to one containing Kinetix 5500 servo drives.

IMPORTANT Migrating from a motion control system that uses Kinetix 2000 servo drives to a system that uses Kinetix 5500 servo drives requires a comprehensive design review of the entire motion control system. There are multiple drive replacement combinations, multiple configurations for how the drives can be installed, and how software is applied. In addition there are system wide changes required because of the communication protocol employed.

As a result, this migration guide is not an all-inclusive document. It does not describe all the redesign steps that may be required, nor does it contain the detailed product information necessary to finalize the redesign. The generalities of the replacement process are covered, and the decision-making steps likely to be encountered in a typical replacement scenario are described.

You will need to review additional product literature (see [Additional Resources on page 10](#)) to understand the technical similarities and differences between the Kinetix 2000 servo drive and a Kinetix 5500 servo drive, and to help you determine the proper solution for your migration.

This migration guide contains these chapters and appendices.

Chapter 1: Servo Drive and System Considerations	Describes some of the primary differences and system design considerations between the drive families.
Chapter 2: Servo Drive and System Comparisons	Provides information on drive sizing, dimension comparison, input wiring / fusing, motor power, cabling, and system layout.
Appendix A: Connectors and Field Connections	Provides information on connector locations, and comparisons for encoder wiring, control wiring, and mains power wiring.
Appendix B: About the Servo Drive System	Provides cut-sheet information about both drive families.
Appendix C: Specifications	Provides comparisons of the power specifications, cable lengths, environmental specifications, and certifications.
Appendix D: Interconnect Diagrams	Provides interconnect diagrams to assist in comparing power wiring and drive connections for both drive families.
Appendix E: Communication Configurations	Provides communication topologies for Kinetix 5500 servo drives.

Kinetix 5500 Servo Drives

The Kinetix 5500 servo drives and Kinetix VP low-inertia servo motors provide a cost-effective motion solution that delivers high performance and scalability with motor windings matched to drive ratings for optimized system sizing.

Enhancing the current midrange architecture portfolio, this motion system is designed to connect and operate with the new family of CompactLogix 5370 controllers by using the Studio 5000 environment and supporting Integrated Motion on the EtherNet/IP network. With the benefits of this motion system, you can now run motion applications on a single control platform by using a single network—simplifying the design, operation, and maintenance of equipment.



Kinetix 5500 Servo Drive Features

The Kinetix 5500 servo drive provides the following features:

- High performance in a smaller footprint and optimized power density
- Single motor cable that includes power, feedback, and brake conductors with SpeedTec connector
- Single-axis operation for low-cost simplicity
- Flexible power connectivity in multi-axis bus-sharing configurations
 - Shared AC
 - Shared DC
 - Shared AC/DC and hybrid configurations
- Integrated motion on the EtherNet/IP network
- Safe torque-off control, ISO-13849-1 certified, PLd, category 3
- Versatile AC input voltage range
 - 195...264V rms, single-phase
 - 195...264V rms, three-phase
 - 324...528V rms, three-phase
- Bulletin VPL winding options that match the drive ratings for optimized system sizing
 - 0.2...14.6 kW continuous output power
 - 1.4...32.5 A 0-pk, continuous output current (inverter)
- Bulletin 2198 capacitor module and Bulletin 2097 shunt resistor for energy absorption management
- Digital (DSL) feedback device provides real-time motor performance information to the control circuitry
 - High-resolution absolute, multi-turn, and single-turn encoder feedback
- Capability to run servo and induction motors

Kinetix 5500 Servo Drive Components

Kinetix 5500 servo drive systems consist of these required components:

- One 2198-H0xx-ERSx servo drive
- One Kinetix VP servo motor, induction motor, or MP-Series rotary motor or linear actuator
 - MP-Series compatibility requires 2198-H2DCK converter kit
- One 2090-CSxM1DF-xxAAxx motor cable for power, feedback, and brake connections
- One 1606-XLxxx 24V power supply for control and motor brake power
- 1585J-M8CBJM-x (shielded) Ethernet cable

Kinetix 5500 servo drive systems can also include any of these optional components:

- One 2198-CAPMOD-1300 capacitor module
- One 2198-DBxx-F AC line filter
- One 2097-Rx shunt resistor
- Bulletin 2198 shared-bus connection system

For detailed Kinetix 5500 servo drive system requirements, see the Kinetix 5500 Servo Drive Systems Design Guide, publication [GMC-RM009](#).

Kinetix 5500 Servo Drive Selection

Kinetix 5500 Servo Drive Cat. No.	Frame Size	Input Voltage	Continuous Output Power kW	Continuous Output Current A 0-pk
2198-H003-ERSx	1	195...264V rms, single-phase 195...264V rms, three-phase 324...528V rms, three-phase	0.2 kW 0.3 kW 0.6 kW	1.4 A
2198-H008-ERSx			0.5 kW 0.8 kW 1.6 kW	3.5 A
2198-H015-ERSx	1.0 kW 1.5 kW 3.2 kW		7.1 A	
2198-H025-ERSx	2		2.4 kW 5.1 kW	11.3 A
2198-H040-ERSx			4.0 kW 8.3 kW	18.4 A
2198-H070-ERSx	3		7.0 kW 14.6 kW	32.5 A

For Kinetix 5500 servo drive module specifications not included in this publication, see the Kinetix Servo Drives Technical Data, publication [GMC-TD003](#).

Pre-migration

Motion Analyzer software – is a comprehensive motion-application sizing tool used for analysis, optimization, selection, and validation of your Kinetix motion control system. This software facilitates the machine design process, letting you quickly design and validate new machine concepts without purchasing or installing physical equipment.

The performance capabilities of any replacement drive should be reviewed to be sure that the replacement drive is capable of delivering the required level of peak and continuous current to the motor and the Motion Analyzer software can assist in the correct drive selection.

Download is available at <http://ab.rockwellautomation.com/motion-control/motion-analyzer-software>.

Controller Files – Upload and save any network files and programmable logic controller (PLC) programs.

Electrical Noise Reduction – See the System Design for Control of Electrical Noise Reference Manual, publication [GMC-RM001](#), for information on the concept of high-frequency (HF) bonding, the ground plane principle, and electrical noise reduction.

Additional Resources

These documents contain additional information concerning related products from Rockwell Automation.

Resource	Description
Integrated Motion on SERCOS and EtherNet/IP Systems - Analysis and Comparison, publication MOTION-WP001	Compare and contrast Integrated Motion systems using SERCOS and EtherNet/IP with a ControlLogix® Programmable Automation Controller (PAC).
Ethernet Design Considerations Reference Manual, publication ENET-RM002	Provides information for designing ethernet and EtherNet/IP networks.
Kinetix 5500 Servo Drives User Manual, publication 2198-UM001	Information on installing, configuring, startup, troubleshooting, and applications for your Kinetix servo drive system.
Kinetix 5500 Drive Systems Design Guide, publication GMC-RM009	System design guide to select the required (drive specific) drive module, power accessory, feedback connector kit, and motor cable catalog numbers for your Kinetix 5500 drive and Kinetix VP motor motion control system.
Logix 5000 Control Systems: Connect Kinetix 5500 Drives over an EtherNet/IP Network, publication IASIMP-QS035	Provides examples and procedures for integrating a Kinetix 5500 servo drive into any Logix 5000™ control system over an EtherNet/IP network.
Kinetix 5500 Servo Drives Installation Instructions, publication 2198-IN001	Information on mounting and wiring the Kinetix 5500 servo drive.
Kinetix 5500 Feedback Connector Kit Installation Instructions, publication 2198-IN002	Information on installing and wiring the Kinetix 5500 motor feedback connector kit.
Kinetix 5500 AC Line Filter Installation Instructions, publication 2198-IN003	Information on installing and wiring the Kinetix 5500 servo drive AC line filters.
Kinetix 5500 Capacitor Module Installation Instructions, publication 2198-IN004	Information on installing and wiring the Kinetix 5500 servo drive capacitor module.
Kinetix 5500 Shared-bus Connector Kit Installation Instructions, publication 2198-IN005	Information on installing the Kinetix 5500 servo drive shared-bus connector kits.
Kinetix 300 Shunt Resistor Installation Instructions, publication 2097-IN002	Information on installing and wiring Kinetix 300 shunt resistors.
System Design for Control of Electrical Noise Reference Manual, publication GMC-RM001	Information, examples, and techniques designed to minimize system failures caused by electrical noise.
EMC Noise Management DVD, publication GMC-SP004	
Kinetix Motion Control Selection Guide, publication GMC-SG001	Overview of Kinetix servo drives, motors, actuators, and motion accessories designed to help make initial decisions for the motion control products best suited for your system requirements.

Resource	Description
Kinetix Rotary Motion Specifications Technical Data, publication GMC-TD001	Product specifications for Kinetix VP (Bulletin VPL), MP-Series™ (Bulletin MPL, MPM, MPF, MPS), Kinetix 6000M (Bulletin MDF), TL-Series™, RDD-Series™, and HPK-Series™ rotary motors.
Kinetix Servo Drives Specifications Technical Data, publication GMC-TD003	Product specifications for Kinetix Integrated Motion over the EtherNet/IP network, Integrated Motion over sercos interface, EtherNet/IP networking, and component servo drive families.
Kinetix 2000 Multi-axis Servo Drives User Manual, publication 2093-UM001	Provides information on how to install, configure, startup, and troubleshoot your Kinetix 2000 servo drive system.
Kinetix 2000 Integrated Axis Module and Axis Module Installation Instructions, publication 2093-IN001	Information on installing the individual modules that comprise a Kinetix 2000 servo drive system
Kinetix 2000 Shunt Module Installation Instructions, publication 2093-IN002	
Kinetix 2000 Slot Filler Module Installation Instructions, publication 2093-IN003	
Kinetix 2000 Power Rail Installation Instructions, publication 2093-IN004	

You can view or download publications at <http://www.rockwellautomation.com/literature>. To order paper copies of technical documentation, contact your local Allen-Bradley® distributor or Rockwell Automation sales representative.

To find your local Rockwell Automation distributor or sales representative, visit <http://www.rockwellautomation.com/locations>.

Notes:

Servo Drive and System Considerations

Replacing a Kinetix 2000 servo drive with a Kinetix 5500 servo drive will require some system design changes as well as drive hardware changes. This chapter describes some of the primary differences and considerations. Additional chapters will provide in-depth drive comparisons.

Engineering Effort and Product Liability

Thoroughly review this document before you begin to evaluate the design changes required to successfully migrate your Kinetix 2000 servo drive to a Kinetix 5500 servo drive.



ATTENTION: Because of the variety of uses for the products described in this publication, those responsible for the application and use of these products must satisfy themselves that all necessary steps have been taken to assure that each application and use meets all performance and safety requirements, including any applicable laws, regulations, codes, and standards. In no event will Rockwell Automation be responsible or liable for indirect or consequential damage resulting from the use or application of these products.

The following sections highlight the major and minor differences between Kinetix 2000 servo drives and Kinetix 5500 servo drives. There may be more differences beyond these that can impact your application. Read this entire document before proceeding to qualify the Kinetix 5500 servo drive for your needs.

Communications

The Kinetix 2000 servo drives use the SERCOS network for communications. A SERCOS interface module serves as a link between the ControlLogix/CompactLogix platform and the Kinetix 2000 servo drive system.

The communication link uses the IEC 61491 SERIAL Real-time COmmunication System (SERCOS) protocol over a fiber-optic media.

The Kinetix 5500 servo drives use the EtherNet/IP network for communicating to either a ControlLogix or CompactLogix programmable automation controller. All Kinetix 5500 servo drives include dual-port Ethernet/IP connectivity.

Supported Ethernet topologies include linear, ring, and star.

For more information on Ethernet design considerations, see these publications:

- Scalability - The Best Approach to Change, publication [IA-WP002](#)

- EtherNet/IP Design, Commissioning, and Troubleshooting Quick Reference, publication [IASIMP-QR023](#)
- Integrated Motion on EtherNet/IP Configuration Drawing with Notes, publication [IASIMP-QR019](#)

See [Appendix E](#) for communication configurations.

Controller, Ethernet Cards, and Switches

The following table lists the compatible hardware for Integrated Motion on EtherNet/IP systems.

Hardware	Description
Controllers	ControlLogix® 1756 L7x and L6x models CompactLogix® 5370 L3y, L2y, and L1y models
Ethernet Communication	1756-EN2T, 1756-EN2TR, and 1756-EN3TR
Ethernet Switches	Stratix 8300™ Layer 3 Modular Managed Ethernet Switches Stratix 8000™ Modular Managed Ethernet Switches Stratix 6000™ Fixed Managed Ethernet Switches Stratix 5700™ Managed Industrial Ethernet Switches Stratix 2000™ Unmanaged Ethernet Switches

Motors

Verify that your existing motor is compatible with the Kinetix 5500 servo drive family. Kinetix 5500 servo drives are compatible with the following motors:

- Kinetix VP series servo motor
- Induction motors
- MP-Series rotary motors
- MP-Series linear actuators

Note: MP-Series compatibility requires a 2198-H2DCK converter kit, and also requires drive firmware revision 2.001 or later, and the Kinetix 5500 servo drive AOP (Add-On Profile) for Studio 5000 Logix Designer™ application, version 21.00.00 or later.

For more information, see Hiperface-to-DSL Feedback Converter Kit Installation Instructions, publication [2198-IN006](#).

For Kinetix 5500 Hiperface-to-DSL Feedback Converter Kit pin-out, see [page 35](#).

In most cases encompass partner motors will work with the converter kit. Check with your local Rockwell sales person or distributor to evaluate compatibility.

Cable Lengths

Verify that the feedback cable length in your current Kinetix 2000 servo drive system does not exceed the maximum cable lengths for the Kinetix 5500 servo drives. The follow are maximum cable lengths for the Kinetix 5500 servo drives:

- Combined motor power cable length for all axes on the same DC bus must not exceed 250 m (820 ft). Drive-to-motor cables must not exceed 50 m (164 ft), however use of continuous-flex cable limits the maximum length. See the Kinetix 5500 Servo Drives User Manual, publication [2198-UM001](#), Table 5 for specifications by frame size.
- Ethernet cable lengths connecting drive-to-drive, drive-to-controller, or drive-to-switch must not exceed 100 m (328 ft). Complete a careful evaluation of your Ethernet media when using a CIP motion solution. For more information, see [Guidance for Selecting Cables for EtherNet/IP Networks](#), publication [ENET-WP007](#).
- Registration and digital input cables greater than 30 m (98.4 ft) must be shielded.

See [Drive Interconnects and Cabling on page 32](#) for more information.

Physical Dimensions

The physical size of the drive families are different (see [Dimension Comparison on page 19](#)). In most cases, the Kinetix 5500 servo drives are smaller and will fit into the existing space of the compatible Kinetix 2000 drives; however, you should verify the physical size of the Kinetix 5500 servo drive.

Control Power

The Kinetix 2000 servo drive integrated axis module (IAM) requires AC input power (230V AC nominal, single phase) for logic circuitry.

The Kinetix 5500 servo drive requires 24V DC input power for control circuitry. You need to review your control power scheme including 24V power supply requirements. See [Appendix C](#) for more information on control power specifications.

Circuit Protection

Sizing for protective devices, such as fuses and circuit breakers, may be different between Kinetix 2000 servo drives and Kinetix 5500 servo drives. Verify that you have chosen the correct sizes when selecting and installing a Kinetix 5500 servo drive. For more information, see [Appendix C](#).

Control Signals

Digital Inputs – It is important to note that the Digital I/O function between the Kinetix 2000 servo drive and Kinetix 5500 servo drive is different.

The Kinetix 2000 servo drive includes six digital inputs. They are Enable, Home, Reg1, Reg2, OT+, and OT-. The drive supplies 24V DC @ 300 mA total for the digital I/O.

The Kinetix 5500 servo drive includes two digital inputs. They are Reg1 and Reg2. The Reg1 input is capable of dual functionality; it can also be used as the Home input. Digital inputs require a 24V DC @ 15 mA supply and should be considered in power supply sizing.

Contactor Enable Relay – The Kinetix 5500 servo drive does not have a Contactor Enable Relay.

Dual Position Loop / Aux Feedback Port – The Kinetix 5500 servo drive does not have the ability to accept an auxiliary encoder input for dual-loop operation or to be used as a Master Input for encoder feedback.

If a Master Encoder input is required, other options are available such as using a Bulletin 842E-CM Integrated Motion on EtherNet/IP™ Absolute Encoder that provides a CIP Motion-capable Master Encoder that can be used with the Kinetix 5500 servo drive or investigate using a Kinetix 6200 or 6500 drive.

Motor Brake – Both servo drive families require a customer-supplied 24V power source for motor-parking brake.

Safe Torque-off Safety Features

Kinetix 5500 servo drives have the capability to safely turn off the inverter power transistors in response to a monitored digital input, according to Category 0 Stop behavior. These drives support parallel input terminals for cascading to adjacent drives over duplex wiring.

For applications that do not require the safety function, you must install jumper wires to bypass the safe torque-off feature.

For the Safe Torque-off connector pinout, installation, and wiring information, see the related chapter in the Kinetix 5500 Servo Drives User Manual, publication [2198-UM001](#).

Accessories

Kinetix 2000 servo drive accessories include the 2093 shunt module, slot-filler modules, line interface module, and AC line filter.

Kinetix 5500 servo drive accessories include the Bulletin 2198 capacitor module, AC line filters, and the shared-bus connection system. Kinetix 5500 servo drives are also compatible with Bulletin 2097 external shunt resistors. See [Accessories on page 40](#).

Servo Drive and System Comparisons

There are a number of different factors that affect the selection of a replacement servo drive and the system redesign effort. They include the following:

- Drive Sizing
- Dimension Comparison
- AC Input Power Wiring and Fusing
- Interconnects and Cabling
- Typical System Layout
- Accessories

This chapter provides a side-by-side comparison of both servo drive families to help in the evaluation and selection of the correct components in the migration process.

Drive Sizing

This section lists the Kinetix 2000 servo drives and the suggested Kinetix 5500 replacement servo drives, along with the output ratings and dimension differences of the drives. Information in this migration guide is based on the drive combinations shown in [Table 1](#) and [Table 2](#).

Output Current Comparison

IMPORTANT The performance capabilities of the replacement drive should be reviewed to be sure that the replacement drive is capable of delivering the required level of peak and continuous current to the motor.

Table 1 - Suggested Kinetix 5500 Replacement Drives by Output Current

Kinetix 2000 Servo Drives				Kinetix 5500 Servo Drives			
Model	Voltage Range (V)	Nominal Voltage Range (V)	Output Current Rating (0-pk) A ⁽¹⁾	Recommended Kinetix 5500 Replacement Drive	Voltage Range (V)	Nominal Voltage Range (V)	Output Current Rating (0-pk) A ⁽¹⁾
2093-AC05-MP1 (IAM) 2093-AMP1	170...264, 1-phase 170...264, 3-phase	230, 1-phase 230, 3-phase	1.4	2198-H003-ERSx	195...264, 1-phase 195...264, 3-phase 324...528, 3-phase	240, 1-phase 240, 3-phase 480, 3-phase	1.4
2093-AC05-MP2 (IAM) 2093-AMP2	170...264, 1-phase 170...264, 3-phase	230, 1-phase 230, 3-phase	2.8	2198-H008-ERSx	195...264, 1-phase 195...264, 3-phase 324...528, 3-phase	240, 1-phase 240, 3-phase 480, 3-phase	3.5
2093-AC05-MP5 (IAM) 2093-AMP5	170...264, 1-phase 170...264, 3-phase	230, 1-phase 230, 3-phase	4.2	2198-H015-ERSx	195...264, 1-phase 195...264, 3-phase 324...528, 3-phase	240, 1-phase 240, 3-phase 480, 3-phase	7.1
2093-AM01	N/A	N/A	8.5	2198-H025-ERSx	195...264, 3-phase 324...528, 3-phase	240, 3-phase 480, 3-phase	11.3
2093-AM02	N/A	N/A	13.4	2198-H040-ERSx	195...264, 3-phase 324...528, 3-phase	240, 3-phase 480, 3-phase	18.4
N/A	N/A	N/A	N/A	2198-H070-ERSx	195...264, 3-phase 324...528, 3-phase	240, 3-phase 480, 3-phase	32.5

(1) Continuous output current ratings are used.

Dimension Comparison

The following table provides a comparison of the dimensions of the drives.

Table 2 - Suggested Kinetix 5500 Replacement Drives by Dimensions

Kinetix 2000 Servo Drive ⁽¹⁾				Kinetix 5500 Servo Drive				Dimension Differences		
Model	Height mm (in)	Width mm (in)	Depth mm (in)	Model	Height mm (in)	Width mm (in)	Depth mm (in)	Height ⁽²⁾ mm	Width ⁽²⁾ mm	Depth ⁽²⁾ mm
2093-AC05-MP1 (IAM)	225 (8.8)	90 (3.5)	192 (7.5)	2198-H003-ERSx	215 (8.46)	50 (1.97)	226 (8.90)	-10	-40	34
2093-AMP1	225 (8.8)	40 (1.6)	192 (7.5)					-10	10	34
2093-AC05-MP2 (IAM)	225 (8.8)	90 (3.5)	192 (7.5)	2198-H008-ERSx	215 (8.46)	50 (1.97)	226 (8.90)	-10	-40	34
2093-AMP2	225 (8.8)	40 (1.6)	192 (7.5)					-10	10	34
2093-AC05-MP5 (IAM)	225 (8.8)	90 (3.5)	192 (7.5)	2198-H015-ERSx	265 (10.43)	55 (2.16)	226 (8.90)	40	-35	34
2093-AMP5	225 (8.8)	40 (1.6)	192 (7.5)					40	15	34
2093-AM01	225 (8.8)	80 (3.1)	192 (7.5)	2198-H025-ERSx	265 (10.43)	55 (2.16)	226 (8.90)	40	-25	34
2093-AM02	225 (8.8)	80 (3.1)	192 (7.5)	2198-H040-ERSx	265 (10.43)	55 (2.16)	226 (8.90)	40	-25	34
N/A	—	—	—	2198-H070-ERSx	294 (11.57)	8.52 (3.35)	226 (8.90)	N/A	N/A	N/A

(1) Dimensions include the motor feedback connector.

(2) A minus sign denotes that the height, width, or depth of the Kinetix 5500 servo drive is shorter, narrower, or shallower than the comparable Kinetix 2000 servo drive.

Dimension Drawings

This section provides dimensions of the drives to assist you in determining the space needed to install the drives.

Kinetix 2000 Servo Drive Dimensions – Integrated Axis Module

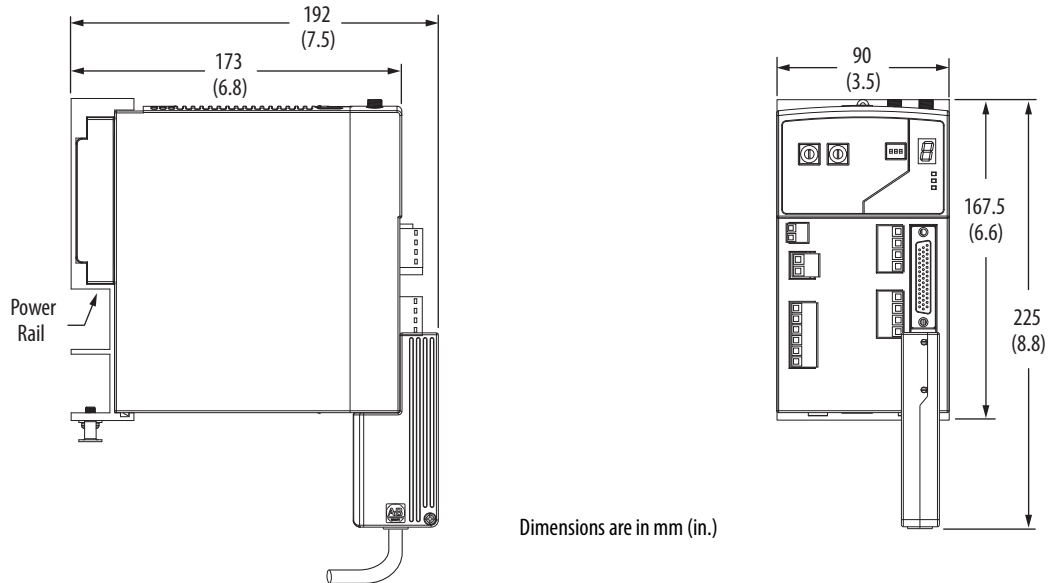

Kinetix 2000 Servo Drive Dimensions – Axis Module

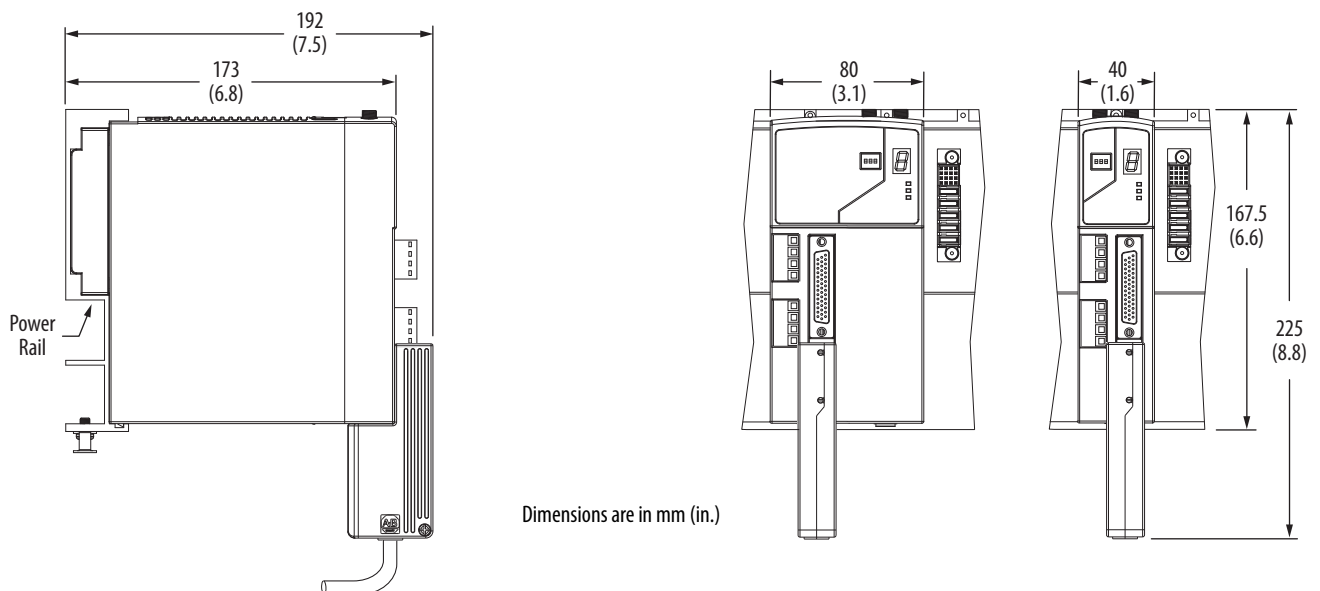

Kinetix 5500 Servo Drive Dimensions

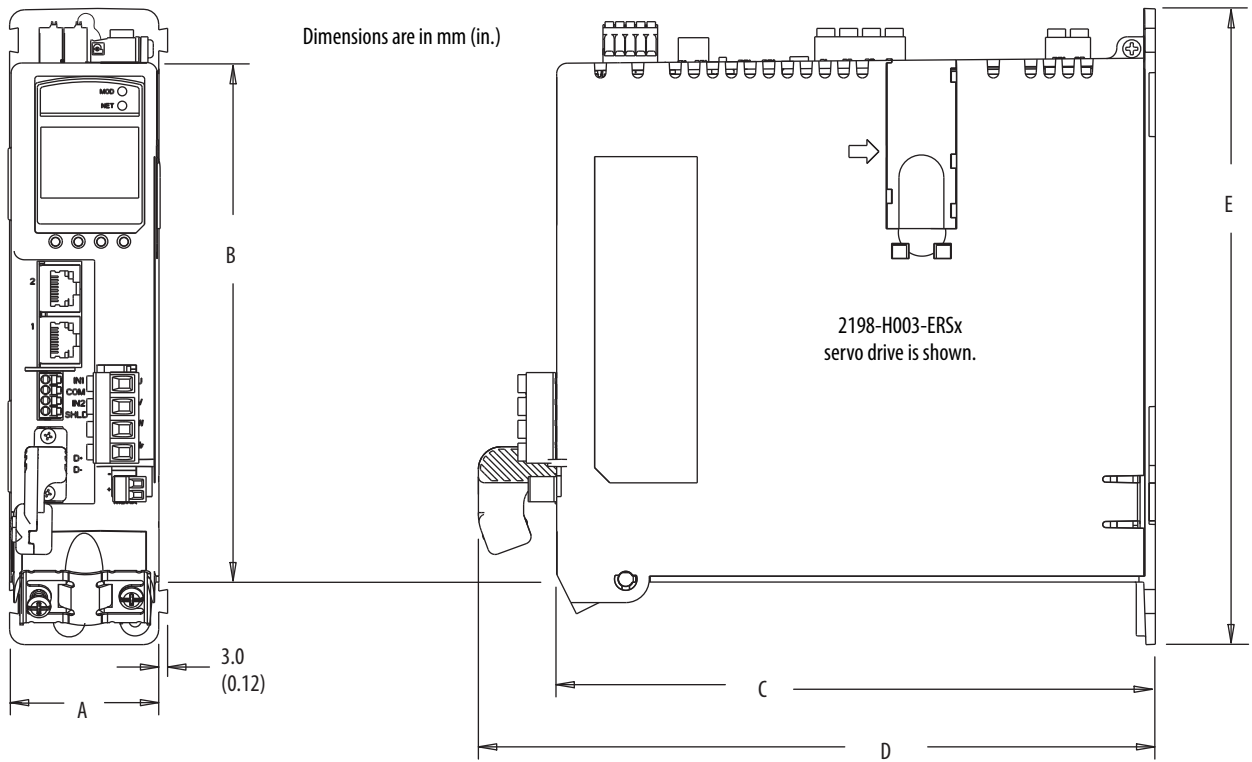

Kinetix 5500 Servo Drive Cat. No.	A mm (in.)	B mm (in.)	C mm (in.)	D mm (in.)	E mm (in.)		
2198-H003-ERSx	50 (1.97)	170 (6.69)	200 (7.87)	226 (8.90)	215 (8.46)		
2198-H008-ERSx							
2198-H015-ERSx	55 (2.16)	225 (8.86)			200 (7.87)	226 (8.90)	265 (10.43)
2198-H025-ERSx							
2198-H040-ERSx							
2198-H070-ERSx	85.2 (3.35)	250 (9.84)					200 (7.87)

AC Input Power Wiring and Fusing

This section provides information to assist you in determining the wiring and fusing requirements of the drives.

AC Input Power Wiring

Determining AC input wiring for the Kinetix 5500 servo drives will require evaluation of which configuration is best for your system. The Kinetix 2000 servo drive accepts AC input to the Integrated Axis Module (IAM) and converts the AC power to DC and that is shared with the other connected Axis Modules (AMs). The Kinetix 5500 servo drives are designed for multiple power configurations. They can be wired independently (single axis) or in multi-axis configurations, including:

- Standalone
- AC/DC Supply Sharing
- DC Bus Sharing
- Hybrid Configuration (consisting of shared AC/DC supply with DC bus)

Kinetix 2000 Servo Drive Input Power Example (with LIM Module)

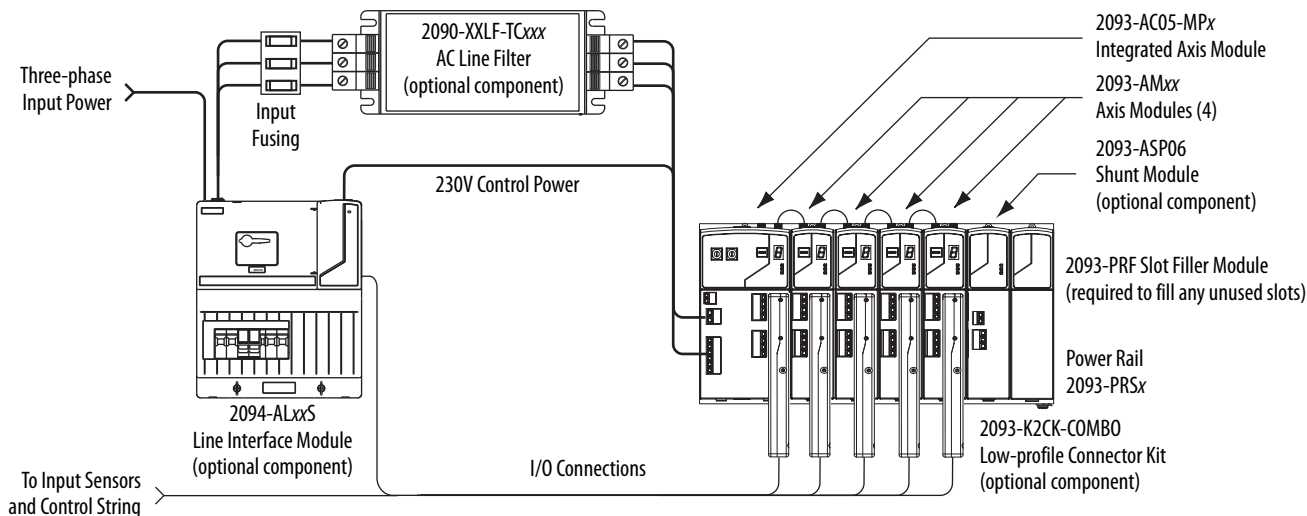

Kinetix 2000 Servo Drive Input Power Example (without LIM Module)

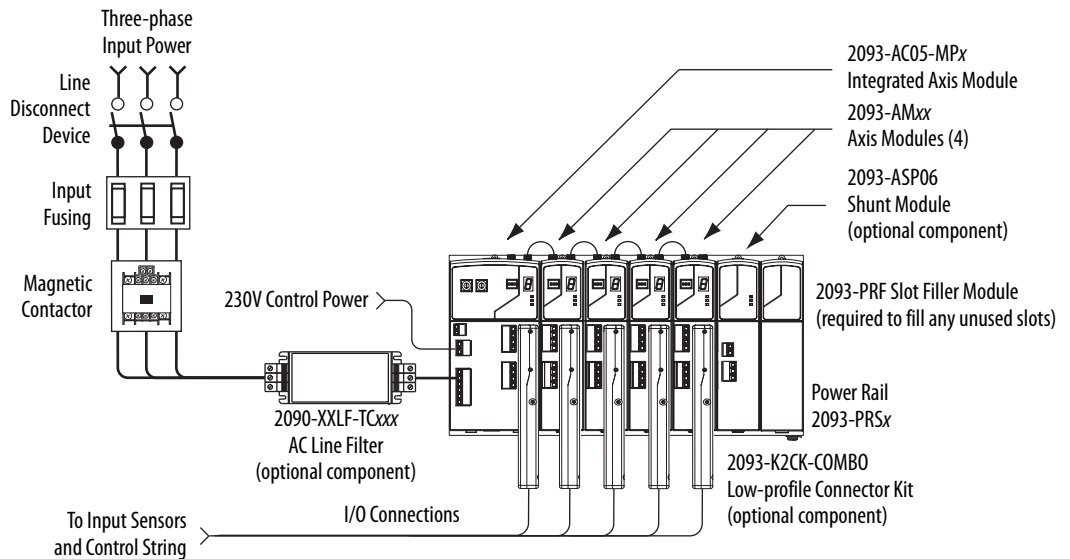

Kinetix 2000 Servo Drive Input Power Example (DC Common Bus)

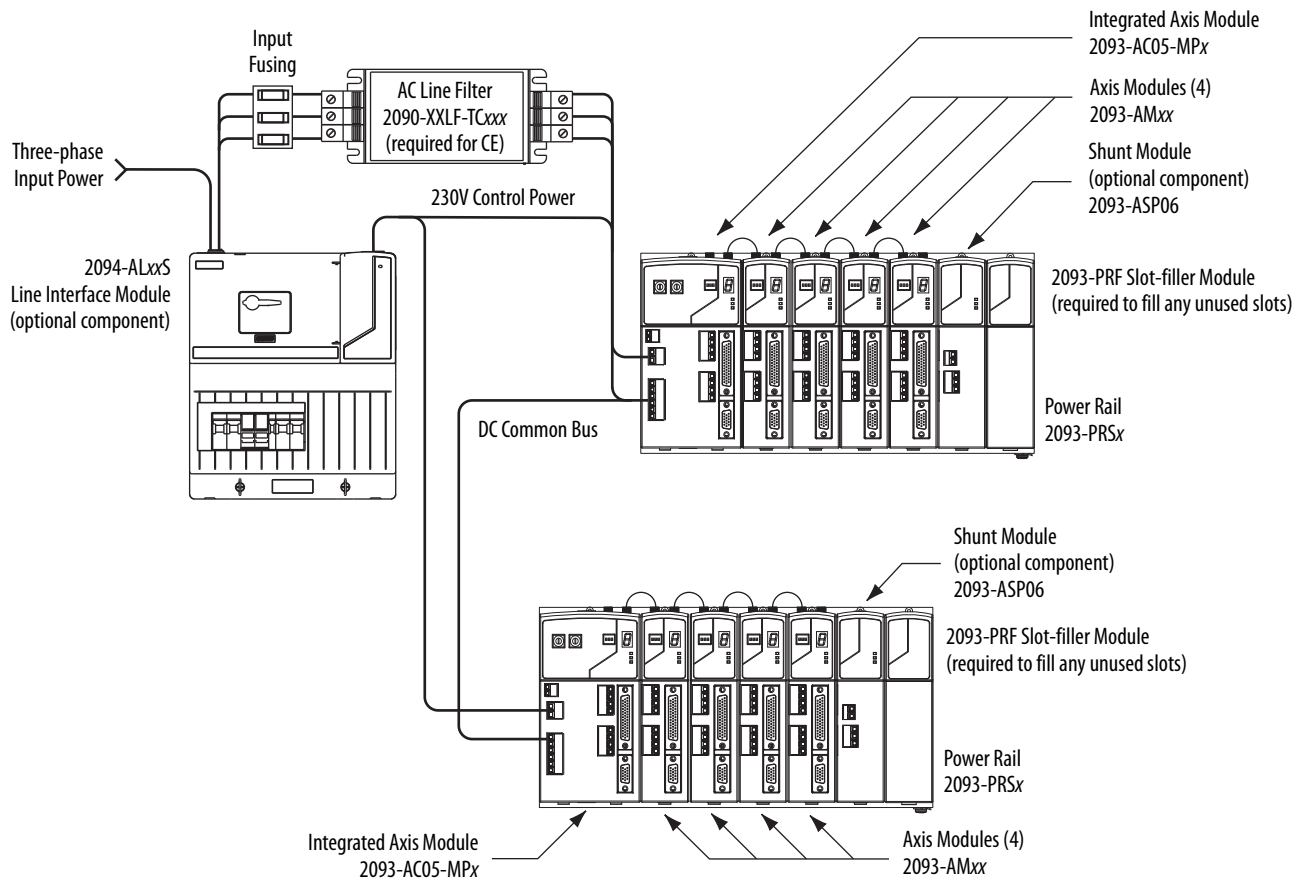

Kinetix 5500 Servo Drive Input Power Example (Standalone)

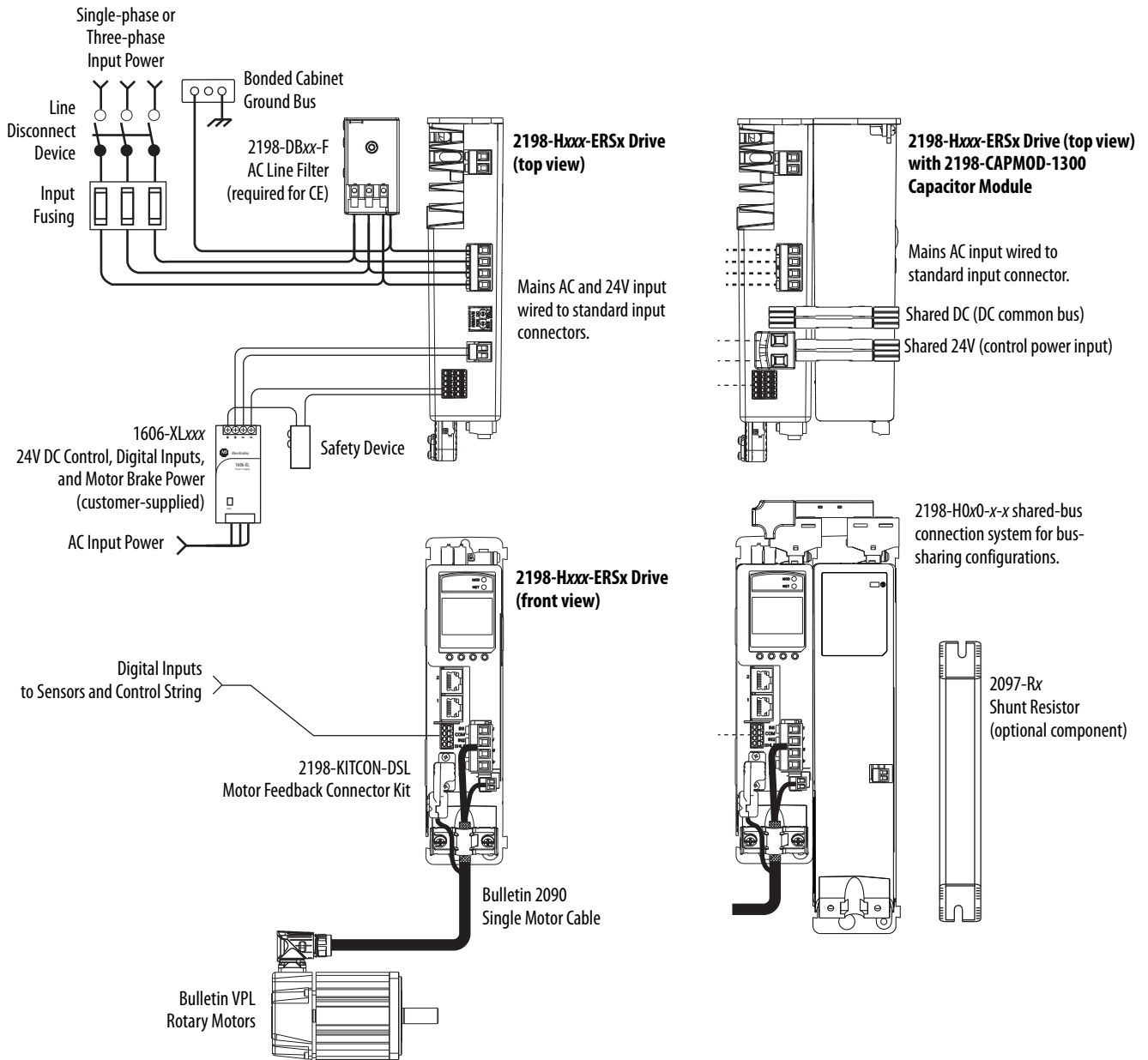

Kinetix 5500 Servo Drive Input Power Example (Shared AC)

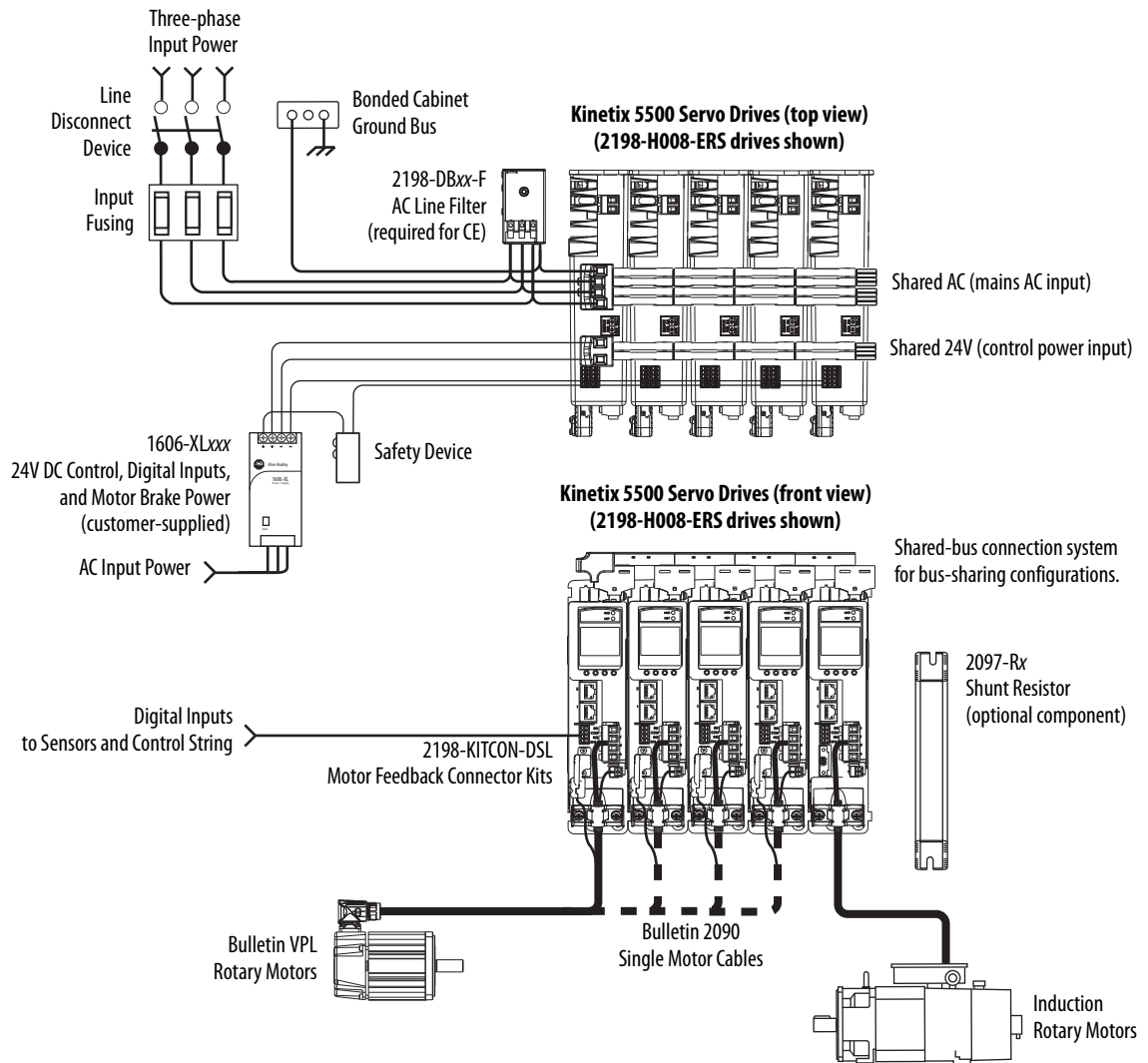

Kinetix 5500 Servo Drive Input Power Example (Shared AC/DC)

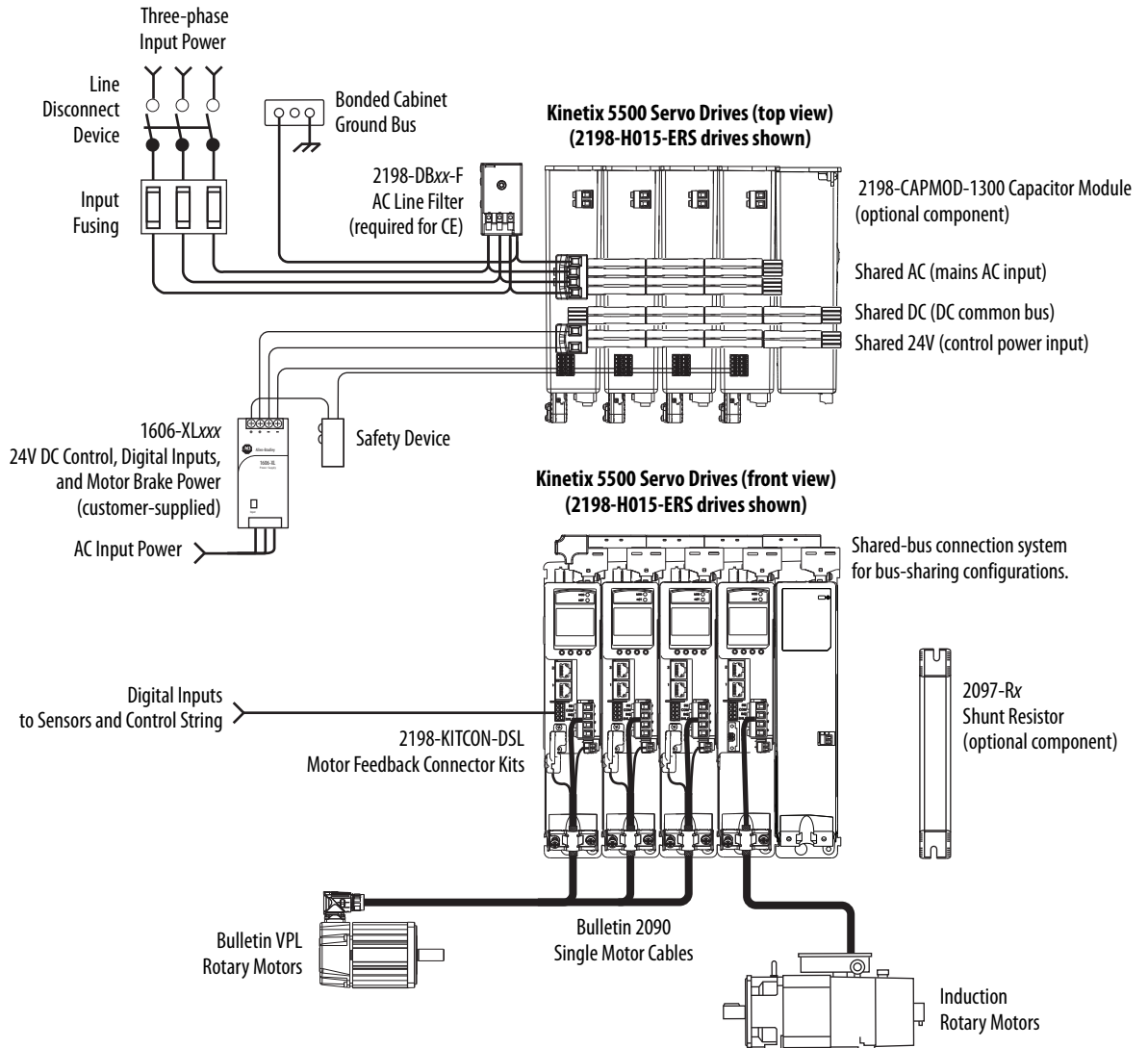

Kinetix 5500 Servo Drive Input Power Example (Common-bus)

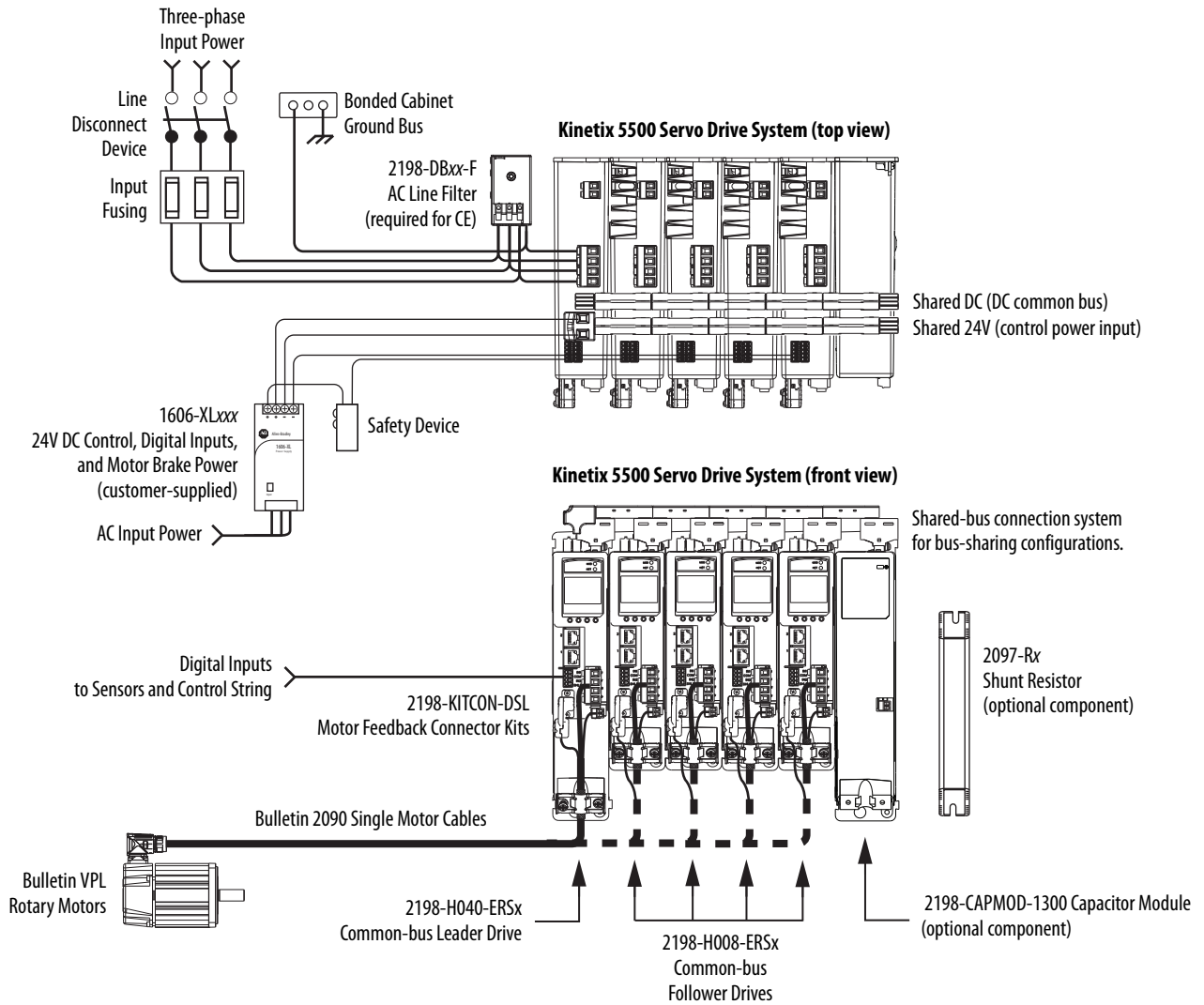

Kinetix 5500 Servo Drive Input Power Example (Shared AC/DC Bus Hybrid)

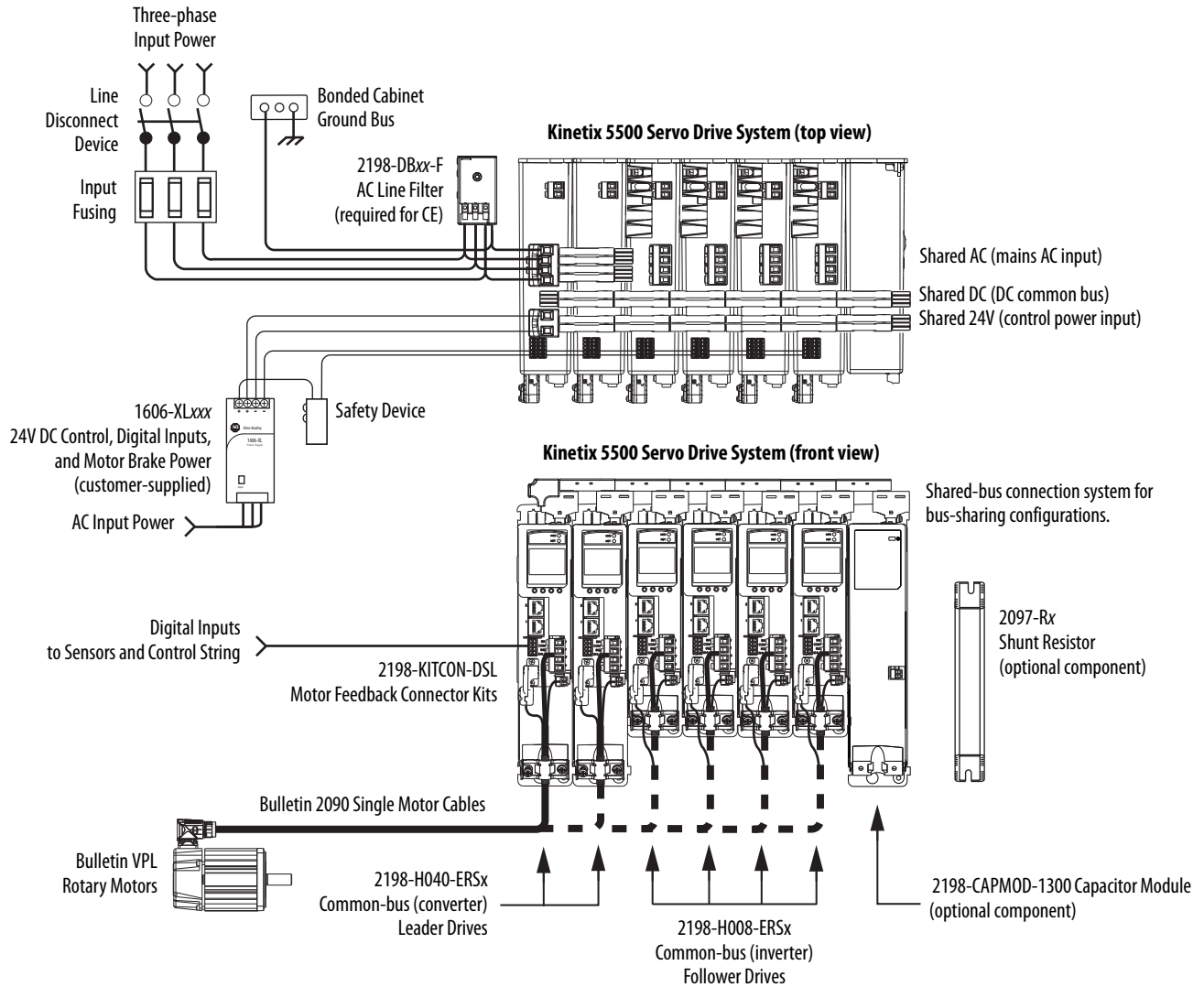

Circuit Breaker and Fuse Considerations

Review the fusing requirements when changing drives.

A Kinetix 2000 servo drive system needs to be protected by a device having a short circuit interrupt current rating of the service capacity provided or a maximum of 100,000 A.

The Kinetix 5500 servo drives use internal solid-state motor short-circuit protection and, when protected by suitable branch circuit protection, are rated for use on a circuit capable of delivering up to 150,000 A.

While circuit breakers offer some convenience, there are limitations for their use. Circuit breakers do not handle high current inrush as well as fuses.

IMPORTANT UL has not approved circuit breakers for use as branch circuit protection for Kinetix 5500 servo drive systems.

Make sure the selected components are properly coordinated and meet acceptable codes including any requirements for branch circuit protection. Evaluation of the short-circuit available current is critical and must be kept below the short-circuit current rating of the circuit breaker.

Kinetix 2000 Servo Drive Main and Control Input Power Fuse Specifications

Use class CC, J, L, or R fuses, with current rating as indicated in the table below. The following fuse examples and Allen-Bradley circuit breakers are recommended for use with integrated axis modules (2093-AC05-MPx) when the Line Interface Module (LIM) is not used.

Table 3 - Main and Control Input Power Fuse Specifications

Kinetix 2000 Servo Drive Cat. No.	Main Input Power				Control Input Power	
	Main Input	Fuse	Circuit Breaker 1492 Series ⁽¹⁾	Circuit Breaker 140M Series ⁽¹⁾	Fuse ⁽²⁾	Circuit Breaker 1492 Series ⁽¹⁾
2093-AC05-MP1	170...264V AC three-phase	KTK-R-20 (20A)	1492-CB3H300	140M-F8E-C16	FNQ-R-10 (10A) or KTK-R-5 (5A)	1492-CB2H060
2093-AC05-MP2						
2093-AC05-MP5						
2093-AC05-MP1	170...264V AC single-phase	KTK-R-20 (20A)	1492-CB3H300	N/A	FNQ-R-10 (10A) or KTK-R-5 (5A)	1492-CB2H060
2093-AC05-MP2						
2093-AC05-MP5						

(1) When using Bulletin 1492 or 140M circuit protection devices, the maximum short circuit current available from the source is limited to 5000 A.
 (2) Fuse selection for control power is appropriate for an eight-axis system with the specified IAM.

Kinetix 5500 Servo Drive Main Input Power Fuse and Circuit Breaker Specifications

The Kinetix 5500 servo drive fuse and circuit breaker selection are dependent on input power configurations.

Table 4 - Standalone Drive Systems Fuse Selection (Bussmann Part No.)

Kinetix 5500 Servo Drive Cat. No.	Three-phase	Single-phase
2198-H003-ERSx	KTK-R-3	KTK-R-2
2198-H008-ERSx	KTK-R-7	KTK-R-5
2198-H015-ERSx	KTK-R-15	KTK-R-10
2198-H025-ERSx	KTK-R-20	N/A
2198-H040-ERSx	KTK-R-25	
2198-H070-ERSx	LPJ-35SP	

Table 5 - Standalone Drive Systems Circuit Breaker Selection (Allen-Bradley Cat. No.)

Kinetix 5500 Servo Drive Cat. No.	Three-phase ⁽¹⁾	Single-phase ⁽¹⁾
2198-H003-ERSx	140U-D6D3-B20	140U-D6D2-B10
2198-H008-ERSx	140U-D6D3-B60	140U-D6D2-B20
2198-H015-ERSx	140U-D6D3-C12	140U-D6D2-B80
2198-H025-ERSx	140U-D6D3-C20	N/A
2198-H040-ERSx	140U-D6D3-C25	
2198-H070-ERSx	N/A	

(1) UL has not approved circuit breakers for use as branch circuit protection for Kinetix 5500 servo drive systems.

Table 6 - Shared DC (Common-bus) Drive Systems Fuse Selection (Bussmann Part No.)

Kinetix 5500 Servo Drive Cat. No.	Three-phase
2198-H003-ERSx	KTK-R-10
2198-H008-ERSx	
2198-H015-ERSx	KTK-R-15
2198-H025-ERSx	KTK-R-20
2198-H040-ERSx	KTK-R-25
2198-H070-ERSx	LPJ-35SP

Table 7 - Shared DC (Common-bus) Drive Systems Circuit Breaker Selection (Allen-Bradley Cat. No.)

Kinetix 5500 Servo Drive Cat. No.	Three-phase ⁽¹⁾
2198-H003-ERSx	N/A
2198-H008-ERSx	
2198-H015-ERSx	140U-D6D3-C15
2198-H025-ERSx	140U-D6D3-C20
2198-H040-ERSx	140U-D6D3-C25
2198-H070-ERSx	N/A

(1) UL has not approved circuit breakers for use as branch circuit protection for Kinetix 5500 servo drive systems.

Table 8 - Shared AC Drive Systems Fuse Selection (Bussmann Part No.)

Kinetix 5500 Servo Drive Cat. No.	2 Axes	3 Axes	4 Axes	5 Axes
2198-H003-ERSx	KTK-R-15			
2198-H008-ERSx	KTK-R-15			
2198-H015-ERSx	KTK-R-20	KTK-R-25	N/A	
2198-H025-ERSx	KTK-R-30		N/A	
2198-H040-ERSx	LPJ-35SP	LPJ-45SP	N/A	
2198-H070-ERSx	LPJ-60SP	N/A		

Table 9 - Shared AC Drive Systems Circuit Breaker Selection (Allen-Bradley Cat. No.)

Kinetix 5500 Servo Drive Cat. No.	2 Axes ⁽¹⁾	3 Axes ⁽¹⁾	4 Axes ⁽¹⁾	5 Axes ⁽¹⁾
2198-H003-ERSx	N/A			
2198-H008-ERSx				
2198-H015-ERSx	140U-D6D3-C15	140U-D6D3-C20	N/A	
2198-H025-ERSx	140U-D6D3-C25	140U-D6D3-C30	N/A	
2198-H040-ERSx	N/A			
2198-H070-ERSxxx	N/A			

(1) UL has not approved circuit breakers for use as branch circuit protection for Kinetix 5500 servo drive systems.

Table 10 - Shared AC/DC and Hybrid Systems Fuse Selection (Bussmann Part No.)

Kinetix 5500 Servo Drive Cat. No.	2 Axes	3 Axes	4 Axes	5 Axes	6 Axes	7 Axes	8 Axes
2198-H003-ERSx	KTK-R-10					KTK-R-15	
2198-H008-ERSx	KTK-R-15				KTK-R-20		
2198-H015-ERSx	KTK-R-20			N/A			
2198-H025-ERSx	KTK-R-30			N/A			
2198-H040-ERSx	KTK-R-30	LPJ-45SP	LPJ-50SP	N/A			
2198-H070-ERSx	LPJ-50SP	N/A					

Table 11 - Shared AC/DC and Hybrid Systems Circuit Breaker Selection (Allen-Bradley Cat. No.)

Kinetix 5500 Servo Drive Cat. No.	2 Axes ⁽¹⁾	3 Axes ⁽¹⁾	4 Axes ⁽¹⁾	5 Axes ⁽¹⁾	6 Axes ⁽¹⁾	7 Axes ⁽¹⁾	8 Axes ⁽¹⁾
2198-H003-ERSx	N/A						
2198-H008-ERSx	N/A						
2198-H015-ERSx	140U-D6D3-C15	140U-D6D3-C20		N/A			
2198-H025-ERSx	140U-D6D3-C20	140U-D6D3-C30		N/A			
2198-H040-ERSx	140U-D6D3-C30	N/A					
2198-H070-ERSx	N/A						

(1) UL has not approved circuit breakers for use as branch circuit protection for Kinetix 5500 servo drive systems.

Drive Interconnects and Cabling

This section provides information to assist you in determining the interconnects and cabling requirements of the drives.

Motor Power and Feedback

The Kinetix 5500 servo drive incorporates a single cable design, which includes both motor power and motor feedback when using a compatible VP-Series motor. The Kinetix 5500 servo drive can also be matched with MP-Series motors and the 2090-xxxx motor power cables can connect directly to the Kinetix 5500 servo drive.

IMPORTANT If you are planning on using an existing MP-Series motor, verify that the existing motor power cable is capable of handling the current delivered to the motor.

For motor feedback the Kinetix 5500 servo drive can be matched with MP-Series motors, but requires the Hiperface-to-DSL Feedback Converter Kit (catalog no. 2198-H2DCK). For more information, see Hiperface-to-DSL Feedback Converter Kit Installation Instructions, publication [2198-IN006](#).

Kinetix 2000 Servo Drives with MP-Series Low Inertia Motors

This section provides system combination information for the Kinetix 2000 (200V class) servo drives when matched with MP-Series™ (200V class) low-inertia motors.

Table 12 - Bulletin MPL Motor Cable Combinations

Motor Cat. No.	Motor Power/Brake Cable
MPL-A1510V-xx7xAA, MPL-A1520U-xx7xAA, MPL-A1530U-xx7xAA	2090-CPxM7DF-16AAxx (standard, non-flex) 2090-CPxM7DF-16AFxx (continuous-flex)
MPL-A210V-xx7xAA, MPL-A220T-xx7xAA, MPL-A230P-xx7xAA	
MPL-A310F-xx7xAA, MPL-A310P-xx7xAA, MPL-A320H-xx7xAA, MPL-A320P-xx7xAA, MPL-A330P-xx7xAA	
MPL-A420P-xx7xAA, MPL-A430H-xx7xAA	
MPL-A4530F-xx7xAA, MPL-A4540C-xx7xAA	

2090-Series Single Motor Cable Overview

Table 13 - Single Motor Cable Descriptions

Single Cable Cat. No. ⁽¹⁾	Description	Cable Configuration		Motor Connector
		Motor End	Drive End	
2090-CSBM1DF-xxAAxx 2090-CSBM1DF-xxAFxx	<ul style="list-style-type: none"> • Drive-end flying-leads (DF) • Power/feedback/brake wires (SB) • Standard, non-flex (AA) • Continuous-flex (AF) 			SpeedTec DIN
2090-CSWM1DF-xxAAxx	<ul style="list-style-type: none"> • Drive-end flying-leads (DF) • Power/feedback wires only (SW) 			

(1) See the Kinetix Motion Accessories Technical Data, publication [GMC-TD004](#), for cable specifications.

Kinetix 5500 (200V-class operation) Servo Drives with Kinetix VP Low Inertia Motors

This section provides system combination information for the Kinetix 5500 servo drives (with 240V, nominal input) when matched with Kinetix VP (200V-class) low-inertia motors.

IMPORTANT Combined motor power cable length for all axes on the same DC bus must not exceed 250 m (820 ft). Drive-to-motor cables must not exceed 50 m (164 ft), however use of continuous-flex cable limits the maximum length. See the Kinetix 5500 Servo Drives User Manual, publication [2198-UM001](#), Table 5 on page 24 for specifications by frame size.

Table 14 - Bulletin VPL Motor Cable Combinations

Motor Cat. No. (200V-class)	Feedback Type	Single Cable Cat. No. ⁽¹⁾
VPL-A063xx	Multi-turn or Single-turn Digital Encoder Feedback	2090-CSBM1DF-18AAxx or 2090-CSWM1DF-18AAxx (standard, non-flex) 2090-CSBM1DF-18AFxx (continuous-flex)
VPL-A0751E, VPL-A0752C, VPL-A0753C		2090-CSBM1DF-14AAxx or 2090-CSWM1DF-14AAxx (standard, non-flex) 2090-CSBM1DF-14AFxx (continuous-flex)
VPL-A0752E, VPL-A0753E		2090-CSBM1DF-18AAxx or 2090-CSWM1DF-18AAxx (standard, non-flex) 2090-CSBM1DF-18AFxx (continuous-flex)
VPL-A1001C		2090-CSBM1DF-14AAxx or 2090-CSWM1DF-14AAxx (standard, non-flex) 2090-CSBM1DF-14AFxx (continuous-flex)
VPL-A1001M, VPL-A1002x, VPL-A1003x		2090-CSBM1DF-14AAxx or 2090-CSWM1DF-14AAxx (standard, non-flex) 2090-CSBM1DF-14AFxx (continuous-flex)
VPL-A1152x, VPL-A1153x		
VPL-A1303x, VPL-A1304x, VPL-A1306x		

(1) Cable length xx is in meters, 01 (3.3) . . . 50 (164) in 1.0 m (3.3 ft) increments. See the Kinetix Motion Accessories Technical Data, publication [GMC-TD004](#), for cable specifications.

Kinetix 5500 (400V-class operation) Servo Drives with Kinetix VP Low Inertia Motors

This section provides system combination information for the Kinetix 5500 servo drives (with 480V, nominal input) when matched with Kinetix VP (400V-class) low-inertia motors.

IMPORTANT Combined motor power cable length for all axes on the same DC bus must not exceed 250 m (820 ft). Drive-to-motor cables must not exceed 50 m (164 ft), however use of continuous-flex cable limits the maximum length. See the Kinetix 5500 Servo Drives User Manual, publication [2198-UM001](#), Table 5 on page 24 for specifications by frame size.

Table 15 - Bulletin VPL Motor Cable Combinations

Motor Cat. No. (400V-class)	Feedback Type	Single Cable Cat. No. ⁽¹⁾
VPL-B063xx	Multi-turn or Single-turn Digital Encoder Feedback	2090-CSBM1DF-18AAxx or 2090-CSWM1DF-18AAxx (standard, non-flex) 2090-CSBM1DF-18AFxx (continuous-flex)
VPL-B0751M, VPL-B0752E, VPL-B0752F, VPL-B0753E, VPL-B0753F		
VPL-B1001M, VPL-B1002E, VPL-B1003C		
VPL-B0752M, VPL-B0753M		2090-CSBM1DF-14AAxx or 2090-CSWM1DF-14AAxx (standard, non-flex) 2090-CSBM1DF-14AFxx (continuous-flex)
VPL-B1002M, VPL-B1003F, VPL-B1003T		
VPL-B1152C		2090-CSBM1DF-18AAxx or 2090-CSWM1DF-18AAxx (standard, non-flex) 2090-CSBM1DF-18AFxx (continuous-flex)
VPL-B1152F, VPL-B1152T, VPL-B1153E, VPL-B1153F		
VPL-B1303x, VPL-B1304x, VPL-B1306x		2090-CSBM1DF-14AAxx or 2090-CSWM1DF-14AAxx (standard, non-flex) 2090-CSBM1DF-14AFxx (continuous-flex)
VPL-B1651C, VPL-B1651F, VPL-B1652C, VPL-B1653C, VPL-B1654B		

(1) Cable length xx is in meters, 01 (3.3) . . . 50 (164) in 1.0 m (3.3 ft) increments. See the Kinetix Motion Accessories Technical Data, publication [GMC-TD004](#), for cable specifications.

Kinetix 5500 Servo Drive Hiperface-to-DSL Feedback Converter Kit

This kit is designed for use with Allen-Bradley® 2090-Series motor feedback cables and provides wire terminations for Hiperface encoder signals to the motor feedback (MF) connector on Kinetix 5500 servo drives with firmware revision 2.001 or later. If needed, the Add-On Profile (AOP) for Kinetix 5500 servo drives is available for download at the Custom Downloads Add-On Profiles website:

<https://download.rockwellautomation.com/esd/download.aspx?downloadid=addonprofiles>

For more information, see Hiperface-to-DSL Feedback Converter Kit Installation Instructions, publication [2198-IN006](#).

Connector Data

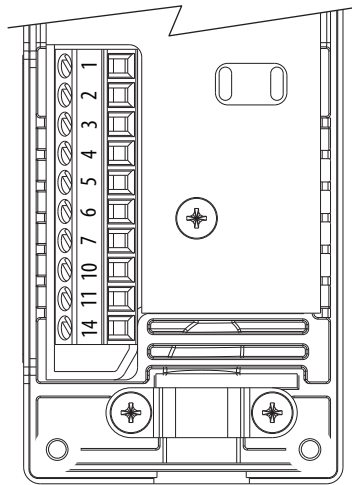

Converter Kit Pinout

Terminal	Signal	Wire Color
1	SIN+	Black
2	SIN-	White/Black
3	COS+	Red
4	COS-	White/Red
5	DATA+	Green
6	ECOM ⁽¹⁾	White/Gray
7	EPWR_9V ⁽²⁾	Orange
10	DATA-	White/Green
11	TS+	White/Orange
14	EPWR_5V ⁽²⁾	Gray

(1) The ECOM and TS- connections are tied together and connect to the cable shield.

(2) The converter kit generates 5V and 9V from a 12V supply coming from the drive. The 5V supply is used by 5V encoders in 230V motors. The 9V supply is used by 9V encoders in 460V motors.

For more information on installing this kit, preparing the cables, and attaching the cable clamps, see the Kinetix 5500 Servo Drive User Manual, publication [2198-UM001](#).

Digital Inputs

This section describes digital inputs for Kinetix 2000 and Kinetix 5500 servo drives.

Kinetix 2000 Servo Drive Digital Inputs

Two fast registration inputs and four other inputs are available for the machine interface on the integrated axis module (IAM) and axis module (AM). Each IAM and AM supplies 24V DC @ 300 mA total for the purpose of registration, home, enable, over-travel positive, and over-travel negative inputs. These are sinking inputs that require a sourcing device. A 24V power and common connection is provided for each input.

IMPORTANT To improve registration input EMC performance, see the System Design for Control of Electrical Noise Reference Manual, publication GMC-RM001.

IMPORTANT Overtravel limit input devices must be normally closed.

Digital Input Signal Specifications

IOD/AF Pin	Signal	Description	System Reaction Time ⁽¹⁾	Edge/Level Sensitive
IOD/AF-43	ENABLE	Optically isolated, single-ended active high signal. Current loading is nominally 10 mA. A 24V DC input is applied to this terminal to activate each axis.	10...21 ms	Level
IOD/AF-40	HOME	Optically isolated, single-ended active high signal. Current loading is nominally 10 mA. Home switch (normally open contact) inputs for each axis require 24V DC (nominal).	10...21 ms	Level
IOD/AF-26 IOD/AF-23	REG1 REG2	Fast registration inputs are required to inform the motor interface to capture the positional information with less than 3 μs uncertainty. Optically isolated, single-ended active high signal. Current loading is nominally 10 mA. A 24V DC input is applied to this terminal to activate each axis.	3 μs	Edge
IOD/AF-37 IOD/AF-29	OT+ OT-	Overtravel detection is available as an optically isolated, single-ended active high signal. Current loading is nominally 10 mA per input. The pos/neg limit switch (normally closed contact) inputs for each axis require 24V DC (nominal).	10...21 ms	Level

(1) System reaction time is a function of the input signal, SERCOS ring time, and application code scan time.

Digital Input Specifications

Parameter	Description	Min	Max	
On-state voltage	Voltage applied to the input, with respect to IOCOM, to guarantee an on-state.	ENABLE, HOME, and OT+/-OT-	10.8V	26.4V
		REG1 and REG2	21.6V	26.4V
On-state current	Current flow to guarantee an on-state.	3.0 mA	10.0 mA	
Off-state voltage	Voltage applied to the input, with respect to IOCOM, to guarantee an off-state.	-1.0V	3.0V	

Kinetix 5500 Servo Drive Digital Inputs

Two digital inputs are available for the machine interface on the IOD connector. Digital inputs require a 24V DC @ 15 mA supply. These are sinking inputs that require a sourcing device. A common and cable shield connection is provided on the IOD connector for digital inputs.

The Registration 1 input is capable of dual functionality. You can also use this as the Home input. Configuration for dual functionality is not needed.

IMPORTANT To improve registration input EMC performance, see the System Design for Control of Electrical Noise Reference Manual, publication [GMC-RM001](#).

Understanding Digital Input Functions

Function	Description	Default Behavior
Home/Reg1	An active state indicates to a homing sequence that the referencing sensor has been seen. Typically, a transition of this signal is used to establish a reference position for the machine axis.	The function is always inactive. You can enable in the Logix Designer application.
Registration 1	An inactive-to-active transition (also known as a positive transition) or active-to-inactive transition (also known as a negative transition) is used to latch position values for use in registration moves.	
Registration 2		

Digital Input Specifications

Attribute	Value
Type	Active high, single-ended, current sinking (EN 61131-2 Type 1)
Dedicated functions	Registration 1, Home, Registration 2
Input current (with 24V applied)	12 mA, typical
On-state input voltage	15...30V @ 15 mA, max
Off-state input voltage	-1.0...5.0V
Pulse reject filtering (registration functions)	12.0 μs
Pulse reject filtering (home input function) debounce filter	20 ms, nom
Propagation delay (registration functions)	0 (delay compensated)
Registration repeatability	700 ns
Windowed registration invalid-to-valid event delay	125 μs, min

Figure 1 - Kinetix 5500 Servo Drive Digital Input Circuitry

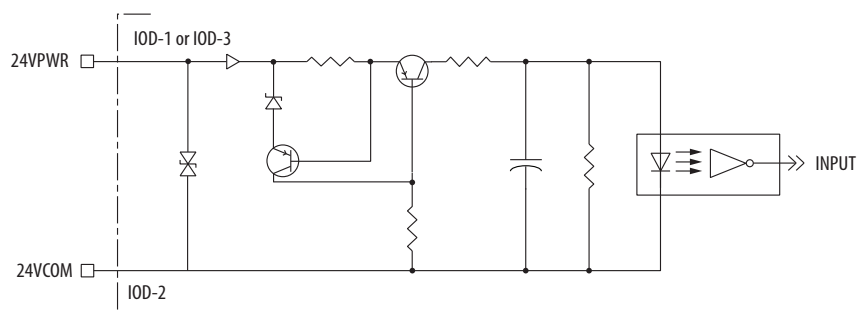

Typical System Layout

This section provides system examples for Kinetix 2000 and Kinetix 5500 servo drives.

Kinetix 2000 Servo System Example

This system example illustrates how the required drive modules and accessories are used in a typical system.

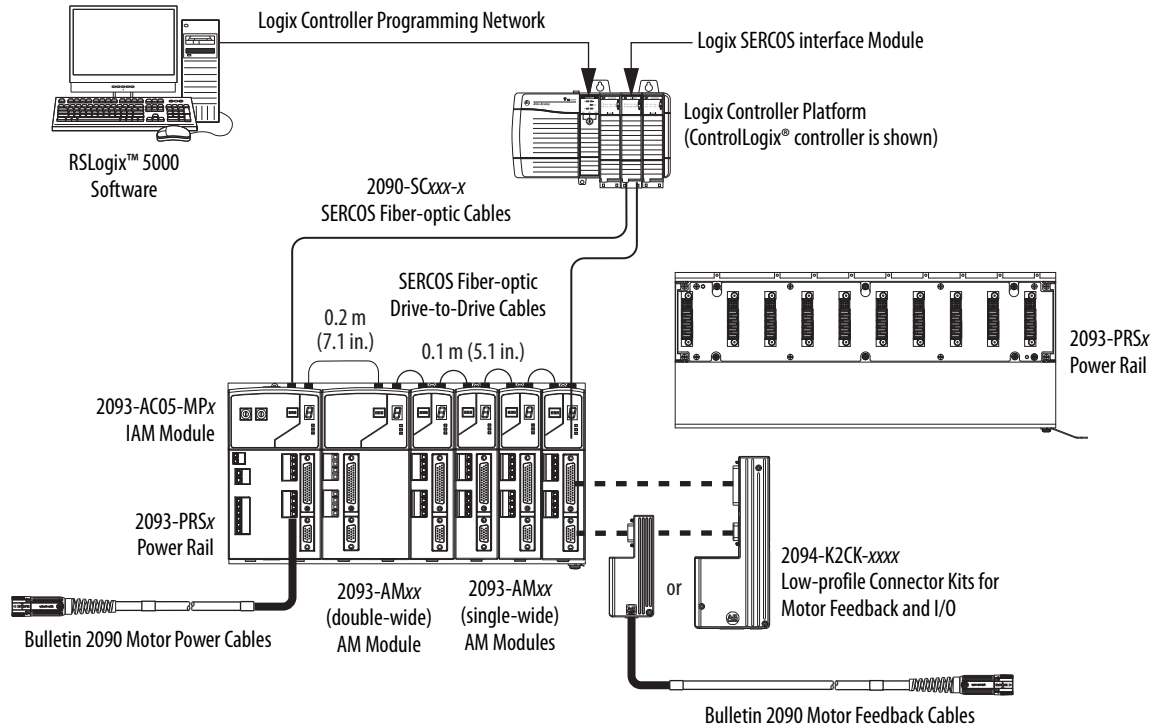

Kinetix 5500 Servo Drive System Example

This example control system uses a Kinetix 5500 standalone servo drive.

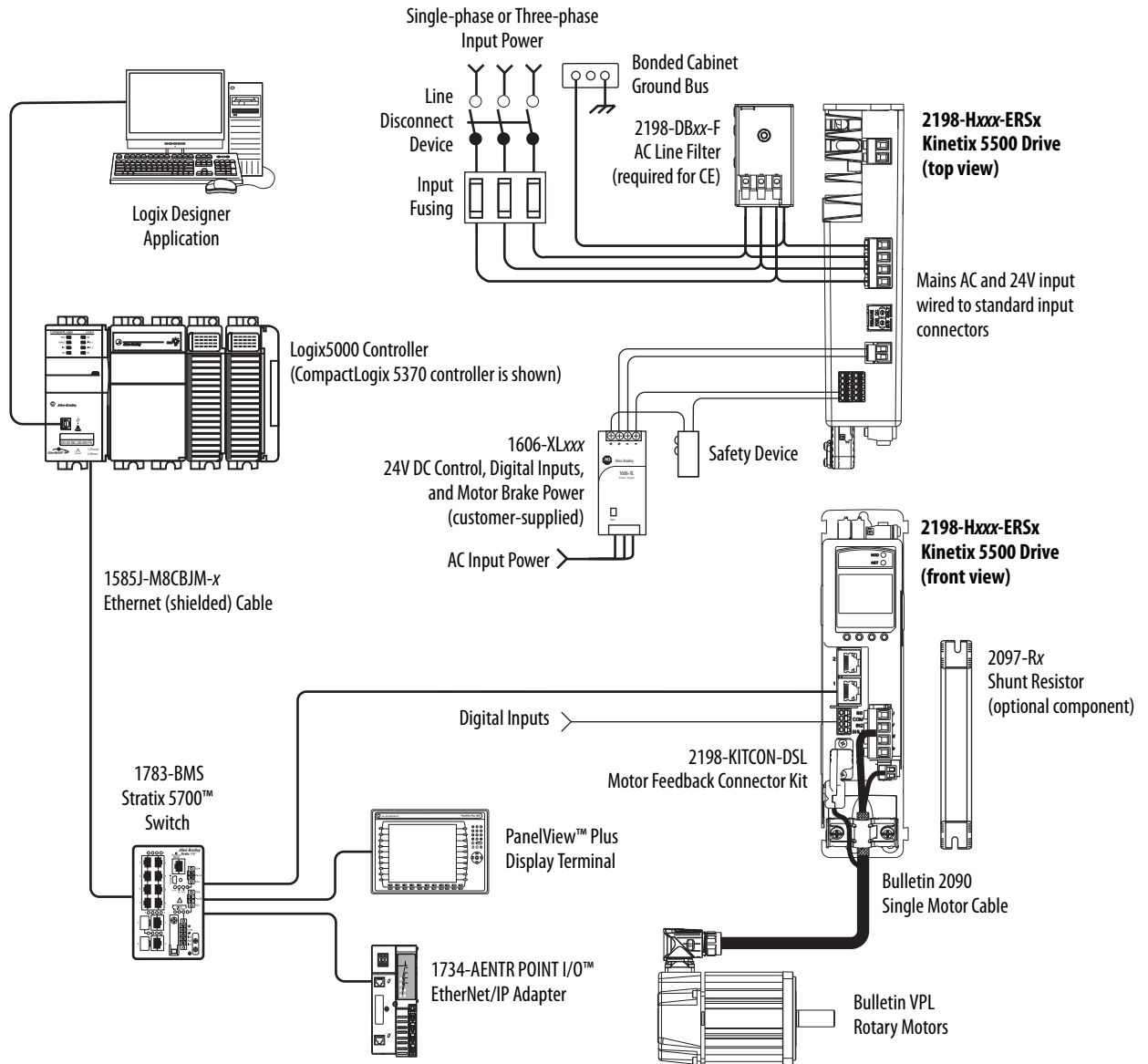

See [Appendix E](#) for additional communication configurations.

Accessories

This section describes required and optional accessories for Kinetix 2000 and Kinetix 5500 servo drives.

Kinetix 2000 Servo Drive Accessories

Table 16 - Required Drive Accessories

Drive Accessory	Description	Cat. No.
2093 power rail	Backplane and mounting fixture for Bulletin 2093 drive modules: available for 1, 2, 3, 4, 5, 7, and 8-axis systems	2093-PRSx
Low-profile connector kits (required for flying-lead cables)	Motor feedback connections (15-pin male, D-sub)	2090-K2CK-D15M
	Motor feedback (15-pin male, D-sub) and I/O (44-pin male, D-sub)	2090-K2CK-COMBO
Backup battery (required to maintain absolute position reference)	Installs in the Bulletin 2090 low-profile connector kits listed above and applies to drive systems that include TLY-Axxxx-B rotary motors and TLAR-Axxxx electric cylinders	2090-DA-BAT2
SERCOS fiber-optic cables (required as needed)	Plastic, in-cabinet duty	2090-SCEPx-x
	Plastic, on-machine duty	2090-SCNPx-x
	Plastic, outdoor, and conduit duty	2090-SCVPx-x
	Glass, outdoor, and conduit duty	2090-SCVGx-x
Motor power and feedback cables	See the specific drive/motor combination for the motor cables required for your system	

See the Kinetix Motion Accessories Technical Data, publication [GMC-TD004](#), for detailed descriptions and specifications of these servo drive accessories.

Table 17 - Optional Drive Accessories

Drive Accessory	Description	Cat. No.
2094 shunt module	50 W continuous shunt power (mounts on power rail)	2093-ASP06
2094 slot-filler module	Fills unused slots on the 2094 power rail	2093-PRF
Bulletin 2094 line interface module (LIM)	Replaces many of the common input power devices for your drive system	2094-ALxxS
		2094-AL09
		2094-XL75S-C2
2090 AC line filters	250V AC, 50/60 Hz, single-phase, EMC	2090-XXLF-TC116
	520V AC, 50/60 Hz, three-phase, EMC	2090-XXLF-TC316
Bulletin 2090 cable clamp bracket kit	Provides stress relief for motor power cable and electrical path from cable shield to machine ground	2090-K2KSCLAMP-4
External auxiliary encoders	Allen-Bradley sine/cosine and incremental external encoders	Bulletin 842A, 844D, 845H, and 845T

Kinetix 5500 Servo Drive Accessories

Table 18 - Required Drive Accessories

Drive Accessory	Description	Cat. No.
24V power supply	24V DC for control power and motor brakes	1606-XLxxx
Ethernet network cables	Double-ended, non-flex, shielded	1585J-M8CBJM-x
	Double-ended, high-flex, shielded	1585J-M8UBJM-x
Motor cables	Refer to the specific drive/motor combination for the motor cable required for your system	2090-CSxM1DF-xxAxxx

TIP The Kinetix 5500 feedback connector kit is included with the drive. Replacement kits are also available.

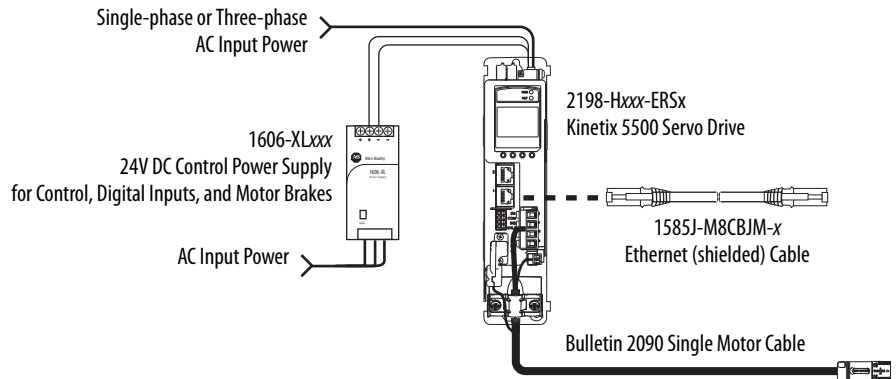
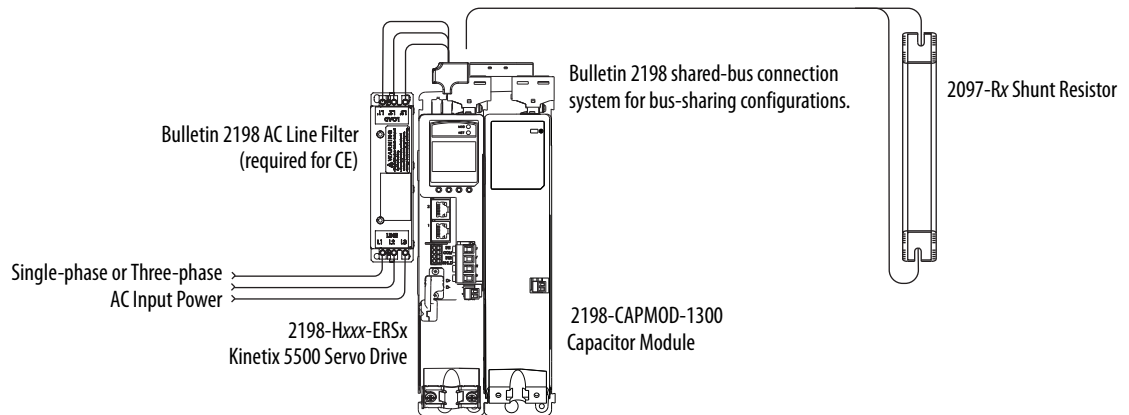

Table 19 - Optional Drive Accessories

Drive Accessory	Description	Cat. No.
Capacitor module	Capacitor bank for energy storage and/or to improve performance in applications that produce regenerative energy and require shorter duty cycles (1360 µf).	2198-CAPMOD-1300
AC line filters	AC line conditioning for EMC.	2198-DBxx-F
Bulletin 2097 shunt resistor	Panel-mount shunt resistor.	2097-Rx
Shared-bus connection system	Input wiring connectors and DC bus T connectors for use between frame 1, 2, and 3 servo drives (frame 3:2, frame 2:1, frame 1:1, and frame 2:2).	2198-H040-x-x
	Input wiring connectors and DC bus T connectors for use between frame 3 servo drives (frame 3:3).	2198-H070-x-x



See the Kinetix Servo Drives Specifications Technical Data, publication [GMC-TD003](#), for detailed descriptions and specifications of these drive accessories.

Notes:

Connectors and Field Connections

Connector Locations

Use these illustrations to identify the connectors and indicators for the Kinetix 2000 and Kinetix 5500 servo drives.

Kinetix 2000 Servo Drive Connector Data

Figure 2 - 2093-AC05-MPx IAM Features and Indicators

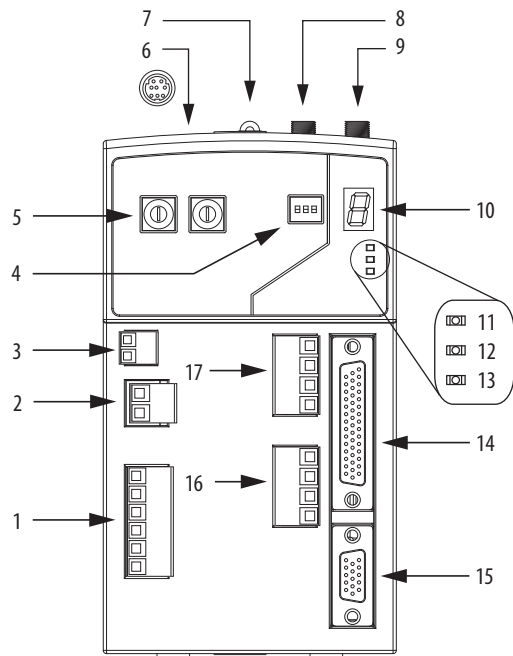

Integrated Axis Module
(2093-AC05-MPx front view)

Item	Description
1	DC Bus / AC input power (IPD) connector
2	Control power (CPD) connector
3	Contactor enable (CED) connector
4	SERCOS communication rate and optical power switches
5	SERCOS node address switch
6	DPI connector (facing up)
7	Mounting screw
8	SERCOS receive (Rx) connector
9	SERCOS transmit (Tx) connector
10	Seven-segment fault status indicator
11	Drive status indicator
12	COMM status indicator
13	Bus status indicator
14	I/O and auxiliary feedback (IOD/AF) connector
15	Motor feedback (MF) connector
16	Motor power (MP) connector
17	Motor brake (BC) connector

Figure 3 - 2093-AMxx AM Features and Indicators

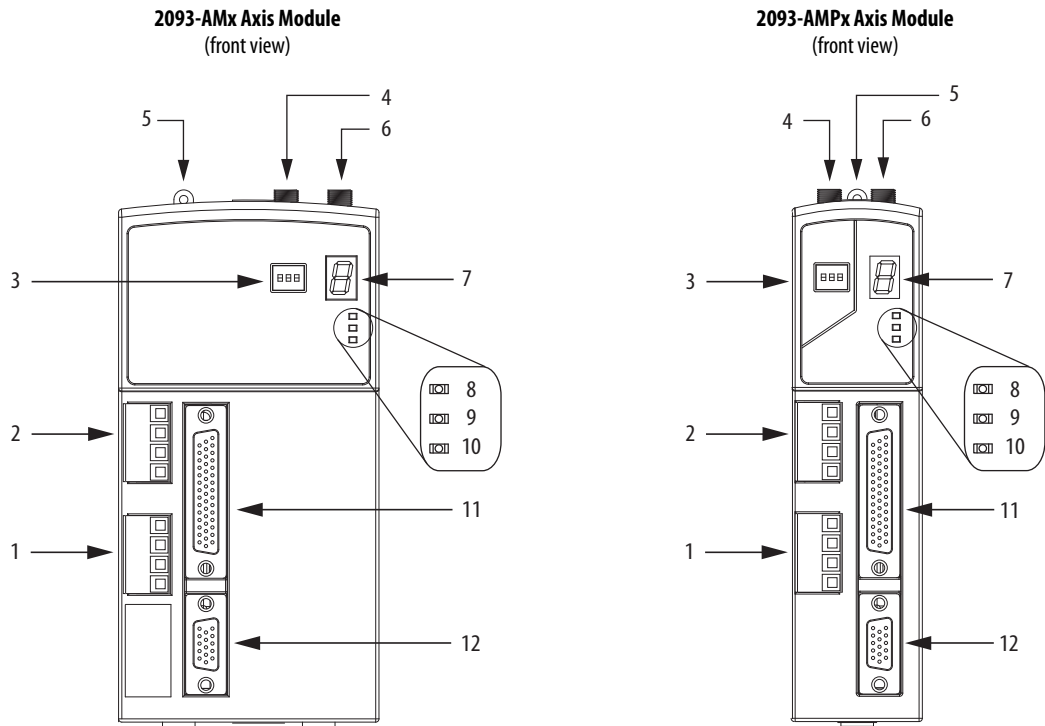

Item	Description
1	Motor power (MP) connector
2	Motor brake (BC) connector
3	SERCOS communication rate and optical power switches
4	SERCOS receive (Rx) connector
5	Mounting screw
6	SERCOS transmit (Tx) connector
7	Seven-segment fault status indicator
8	Drive status indicator
9	COMM status indicator
10	Bus status indicator
11	I/O and auxiliary feedback (IOD/AF) connector
12	Motor feedback (MF) connector

Kinetix 5500 Servo Drive Connector Data

Figure 4 - Drive Features and Indicators

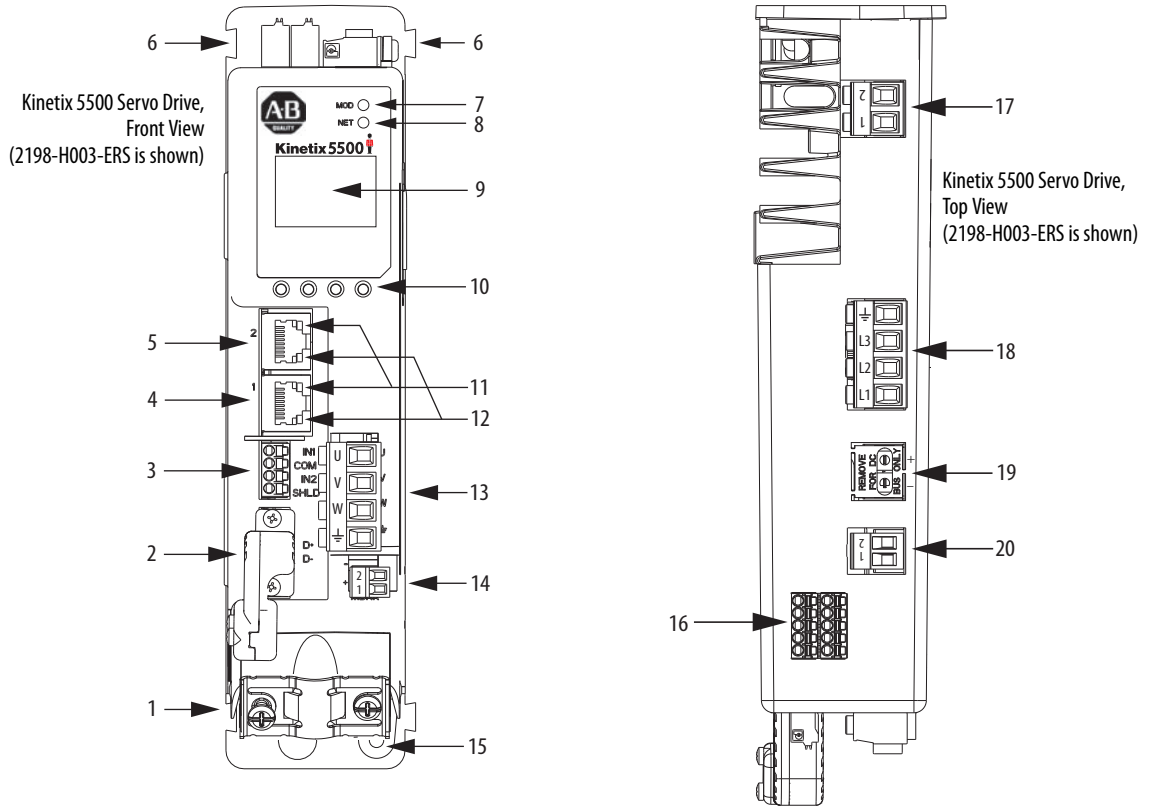

Item	Description
1	Motor cable clamp
2	Motor feedback (MF) connector
3	Digital inputs (IOD) connector
4	Ethernet (PORT1) RJ45 connector
5	Ethernet (PORT2) RJ45 connector
6	Zero-stack mounting tab/cutout
7	Module status indicator
8	Network status indicator
9	LCD display
10	Navigation pushbuttons

Item	Description
11	Link speed status indicators
12	Link/Activity status indicators
13	Motor power (MP) connector
14	Motor brake (BC) connector
15	Ground terminal
16	Safe torque-off (STO) connector
17	Shunt resistor (RC) connector
18	AC mains input power (IPD) connector
19	DC bus (DC) connector (under cover) ⁽¹⁾
20	24V control input power (CP) connector

(1) The DC bus connector ships with a protective knock-out cover that can be removed for use in shared-bus configurations.

Input Power Connector Pinouts

The table below compares the input power, control power, contactor enable, and shunt resistor connector pinouts for the Kinetix 2000 IAM and Kinetix 5500 servo drives:

- Kinetix 2000 IAM servo drive IPD, CPD and CED connectors
- Kinetix 5500 servo drive IPD, DC, CP and RC connectors

Description	Kinetix 2000 Servo Drives ⁽¹⁾			Kinetix 5500 Servo Drives		
	Connector	Signal	Terminal	Connector	Signal	Terminal
Three-phase Input Power	IPD	L1	1	IPD	L1	L1
		L2	2		L2	L2
		L3	3		L3	L3
Chassis Ground		Ground	4	Ground	Ground	
DC Bus Connections		DC+	5	DC	DC-	1
		DC-	6		DC+	2
Control Power	CPD	CTRL 1	1	CP	24V	24V+
		CTRL 2	2		24V Com	24 -
Contactor Enable ⁽²⁾	CED	CONT EN+	1			
		CONT EN-	2			
Shunt Resistor				RC	DC+ ⁽³⁾	1
					SH ⁽³⁾	2
					SH ⁽⁴⁾	1
					DC+ ⁽⁴⁾	2

(1) These connections have removable wiring plugs. The pins are numbered consecutively from top to bottom, and keyed to prevent incorrect insertion.

(2) Relay-driven dry contact used in the safety string for a three-phase power contactor.

(3) Shunt connections (Frames 2 and 3).

(4) Shunt connections (Frame 1).

Motor Power and Brake Pinouts

The table below compares the motor power and brake connector pinouts for the Kinetix 2000 IAM/AM and Kinetix 5500 servo drives:

- Kinetix 2000 IAM/AM servo drive MP and BC connectors
- Kinetix 5500 servo drive MP and BC connectors

Description	Kinetix 2000 IAM / AM Servo Drives ⁽¹⁾			Kinetix 5500 Servo Drives		
	Connector	Signal	Terminal	Connector	Signal	Terminal
Three-phase Motor Power ⁽²⁾	MP	U	1	MP	U	U
		V	2		V	V
		W	3		W	W
		Ground	4		Ground	Ground
Chassis Ground						
24V Brake Input Power	BC	PWR	1	BR		
Motor Brake Connections		MBRK+	2		MBRK+	1
		MBRK-	3		MBRK-	2
		24V Common	COM		4	

(1) These connections have removable wiring plugs. The pins are numbered consecutively from top to bottom, and keyed to prevent incorrect insertion.

(2) Kinetix 2000: Drive-to-motor power cables must not exceed 90 m (295.5 ft). To meet CE requirements, combined motor power cable length for all axes on the same DC bus must not exceed 160 m (525 ft) with 230V systems.
Kinetix 5500: Drive-to-motor power cables must not exceed 50 m (164 ft). System performance was tested at this cable length. These limitations also apply when meeting CE requirements.

Encoder Connector Pinouts

The table below compares the feedback connector pinouts for the Kinetix 2000 IAM/AM and Kinetix 5500 servo drives:

- Kinetix 2000 IAM/AM servo drive MF connector
- Kinetix 5500 servo drive MF connector

Kinetix 2000 Servo Drives ⁽¹⁾			Kinetix 5500 Servo Drives ⁽²⁾		
MF Pin	Description	Signal	Signal	Description	MF Pin
1	Channel A+ / sine differential input+	AM+	—	—	—
2	Channel A- / sine differential input-	AM-	—	—	—
3	Channel B+ / cosine differential input+	BM+	—	—	—
4	Channel B- / cosine differential input-	BM-	—	—	—
5	DATA+ / Channel I+ / Index pulse+	DATA+ /IM+	—	—	—
6	Common	ECOM	—	—	—
7	N/C / Encoder power (+9V)	EPWR +9V	—	—	—
8	Commutation channel S3	S3	—	—	—
9	Positive overtravel limit	E_OT+	—	—	—
10	DATA- / Channel I- / Index pulse-	DATA- /IM-	—	—	—
11	Thermostat	TS	—	—	—
12	Commutation channel S1	S1	—	—	—
13	Commutation channel S2	S2	—	—	—
14	Encoder power (+5V)	EPWR_5V	—	—	—
15	Negative overtravel limit	E_OT-	—	—	—
—	—	—	D+	Bidirectional data and power for digital encoder interface ⁽³⁾	1
—	—	—	D-		2
—	—	—	SHIELD		SHIELD

(1) Connections vary based on supported encoder used.

(2) Connections shown for VPL motor encoder.

(3) Kinetix 5500 servo drive-to-motor power cables must not exceed 50 m (164 ft). System performance was tested at this cable length. These limitations also apply when meeting CE requirements.

I/O Connector Pinouts

The table below compares the I/O connector pinouts for the Kinetix 2000 IAM/AM and Kinetix 5500 servo drives:

- Kinetix 2000 IAM/AM IOD/AF connector
- Kinetix 5500 servo drive IOD connector

Kinetix 2000 Servo Drives			Kinetix 5500 Servo Drives		
IOD/AF Pin	Description	Signal	Signal	Description	IOD Pin
1...15	Reserved	—			
16	Data/index positive differential input/output	DATA+ / I+			
17	Data/index negative differential input/output	DATA- / I-			
18	Encoder 5V power supply	EPWR_5V			
19	Encoder common	ECOM			
20	Encoder 9V power supply	EPWR_9V			
21	Reserved	—			
22	Registration input 2 common	24VCOM_REG2	IN2	High speed registration input. A low/high or high/low transition triggers a registration event.	3
23	Registration input 2	REG2			
24	Registration input 2 24V	24V_REG2	IN1 (1)	High speed registration /home position input. A low/high or high/low transition triggers a registration event. This is a dual-function input.	1
25	Registration input 1 common	24VCOM_REG1			
26	Registration input 1	REG1			
27	Registration input 1 24V	24V_REG1			
28	24V common	24VCOM			
29	Overtravel input negative	OT-			
30	24V power output	24VPWR			
31	Sine / A positive differential input	SINE+/A+			
32	Sine / A negative differential input	SINE-/A-			
33	Cosine / B positive differential input	COSINE+/B+			
34	Cosine / B negative differential input	COSINE-/B-			
35	Reserved	—			
36	24V common	24VCOM			
37	Overtravel input positive	OT+			
38	24V power output	24VPWR	COM	I/O common for customer-supplied 24V supply.	2
39	24V common	24VCOM	IN1	High speed registration /home position input. A low/high or high/low transition triggers a registration event. This is a dual-function input.	1
40	Home input	HOME			
41	24V power output	24VPWR			
42	24V common	24VCOM			
43	Enable	ENABLE			
44	24V power	24VPWR			

(1) This signal has dual-functionality. You can use IN1 (IOD-1) as registration or Home input.

Notes:

About the Servo Drive System

About the Kinetix 2000 Servo Drive System

The Kinetix 2000 multi-axis servo drive is designed to provide a Kinetix Integrated Motion solution for applications with output power requirements between 3...45 kW (4...49 A).

Table 20 - Kinetix 2000 Servo Drive System Overview

Kinetix 2000 Servo Drive Component	Cat. No.	Description
Integrated Axis Module	2093-AC05-MPx	Integrated Axis Module (IAM) mounts on a Kinetix 2000 power rail, and is a 230V AC power converter and inverter. It is installed on a Kinetix 2000 power rail.
Axis Module	2093-AMxx	Axis Module (AM), is a shared 230V DC bus power inverter, that mounts on a Kinetix 2000 power rail. The AM must be used with an IAM.
	2093-AMPx	
Shunt Module	2093-ASP06	Shunt Module (SM), This module mounts on the Kinetix 2000 power rail and provides additional shunting capability in regenerative applications.
Power Rail	2093-PRSxx	Power Rail (PR) consists of copper bus bars and a circuit board with connectors for each module. The power rail provides power and control signals from the converter section to adjacent inverters. The IAM, AM, SM, and SF modules mount to the power rail.
Power Rail Slot Filler	2093-PRF	Slot Filler (SF) is used when one or more slots on the Kinetix 2000 power rail are empty after all other power rail components are installed. One slot filler is required for each empty slot.
Logix Controller Platform	1756-L60M03SE, 1756-MxxSE, and 1768-M04SE modules, and the 1784-PM16SE PCI card	SERCOS interface module/PCI card serves as a link between the ControlLogix/CompactLogix/SoftLogix platform and Kinetix 2000 drive system. The communication link uses the IEC 61491 Serial Real-time COmmunication System (SERCOS) protocol over a fiber-optic cable.
RSLogix 5000 Software	9324-RLD300ENE	RSLogix 5000 software provides support for programming, commissioning, and maintaining the Logix family of controllers.
Servo Motors	MP-Series, TL-Series, and Y-Series	Compatible servo motors include the MP-Series (Low Inertia, Food Grade, and Stainless Steel) 230V motors; TL-Series motors; and Y-Series motors.
Integrated Linear Actuators	MP-Series	Compatible linear actuators include the MPAI-Axxx (Integrated Actuator) 230V actuators.
Cables	Motor Power, Feedback, and Brake cables	Motor power, feedback, and brake cables include integral molded, bayonet style, quick connect/quick-release connectors at the motor. Power and brake cables have flying leads on the drive end and straight connectors that connect to servo motors. Standard feedback cables have angled connectors (45°) on the drive end and straight connectors that connect to servo motors. Optional feedback cables have a straight connector on the motor end and flying leads that wire to a low-profile connector kit on the drive end.
	Fiber-optic cables	SERCOS fiber-optic cables are available in enclosure only, PVC, nylon, and glass with connectors at both ends.
Line Filters, AC	2090-XXLF-xxxx	Bulletin 2090-XXLF-xxxx single-phase and three-phase AC line filters are required to meet CE and available for use in 230V systems.
Line Interface Module	2094-AL09, 2094-AL15S, 2094-AL25S, 2094-AL50S, 2094-AL75S, 2094-AL75S-C2	Line Interface Module (LIM), contains the circuit breakers, AC line filter, power supplies, and contactor required for Kinetix 2000 servo drive operation. This module does not mount to the power rail. Alternatively, individual components may be purchased in place of a LIM.

About the Kinetix 5500 Servo Drive System

The Kinetix 5500 servo drives are designed to provide a Kinetix Integrated Motion solution for your drive/motor application.

Table 21 - Kinetix 5500 Servo Drive System Overview

Drive System Component	Cat. No.	Description
Kinetix 5500 Servo Drives	2198-Hxxx-ERSx	200V-class (single-phase or three-phase) and 400V-class (three-phase) drives operate in standalone and multi-axis shared AC, shared DC, shared AC/DC, and shared AC/DC hybrid configurations. Modules are zero-stacked from drive-to-drive and use the shared-bus connection system to extend power in multi-axis configurations.
Kinetix 5500 Capacitor Module	2198-CAPMOD-1300	Used for energy storage and/or to improve performance in applications producing regenerative energy and requiring shorter duty cycles (1360 µf). Modules are zero-stacked side-by-side with servo drives and use the shared-bus connection system to extend power.
Shared-bus Connector Kits	2198-H040-x-x	Input wiring connectors and DC bus T-connector for frame 1 and 2 servo drives.
	2198-H070-x-x	Input wiring connectors and DC bus T-connector for frame 3 servo drives.
Feedback Connector Kit	2198-KITCON-DSL	Replacement feedback connector kit with 2-pin connector plug and grounding plate inside the connector housing.
I/O Connector Kits	2198-KITCON-IOSP	Replacement I/O connector kit (spring clamp) for I/O (IOD) connector.
	2198-KITCON-IOSC	Replacement I/O connector kit (screw terminal) for I/O (IOD) connector.
Connector Sets	2198-KITCON-PWR40	Replacement connector set, 40 A, for frame 1 and frame 2 drives.
	2198-KITCON-PWR70	Replacement connector set, 70 A, for frame 3 drives.
	2198-KITCON-CAP1300	Replacement connector set, 40 A, for capacitor module.
Logix5000 Controller Platform	1769-L18ERM 1769-L27ERM 1769-L30ERM 1769-L33ERM 1769-L36ERM	CompactLogix 5370 controllers with Integrated Motion on the EtherNet/IP network. Linear, ring, and star topology is supported.
	1756-EN2T module 1756-EN2TR module 1756-EN3TR module	ControlLogix 1756-L7x controllers with Integrated Motion on EtherNet/IP networks. Linear, device-level ring (DLR), and star topology is supported.
Studio 5000	N/A	Studio 5000 Logix Designer application, version 21.00 or later, provides support for programming, commissioning, and maintaining the CompactLogix and ControlLogix controller families.
Compatible Motors	VPL-Axxxx VPL-Bxxxx	Compatible rotary motors include 200V and 400V-class Kinetix VP (Bulletin VPL) servo motors.
	N/A	Induction motors with open loop volts/hertz frequency control are also supported.
Cables	2090-CSxM1DF-xxAAxx	Bulletin 2090 single-cable for motor power, feedback, and 24V DC brake power.
	1585J-M8CBJM-x	Ethernet cables are available in standard lengths. Shielded cable is recommended.
AC Line Filters	2198-DB08-F 2198-DB20-F 2198-DB42-F	Bulletin 2198 three-phase AC line filters are required to meet CE and available for use in all Kinetix 5500 servo drive systems.
24V DC Power Supply	1606-XLxxx	Bulletin 1606 24V DC power supply for control circuitry, digital inputs, safety, and motor brake.
External Shunt Resistors	2097-R6 and 2097-R7	Bulletin 2097 external passive shunt resistors for when the drive's internal shunt capability is exceeded.

Specifications

Power Specifications

Kinetix 2000 Servo Drive Converter Power Specifications

The following table lists power specifications for the converter section that resides within an integrated axis module.

Table 22 - IAM Converter (Three-phase and Single-phase) Power Specifications

Attribute	2093-AC05-MPx Three-phase Input (230V nom)	2093-AC05-MPx Single-phase Input (230V nom)
Input voltage, AC	170...264V rms	
Input frequency, AC	47...63 Hz	
Input current, AC main ⁽¹⁾ Nom (rms) Max inrush (0-pk)	11.66 A 34.0 A	10.95 A 34.0 A
Input voltage, DC (common bus follower)	240...375V DC	
Input current, DC (common bus follower)	9.76 A	6.42 A
Control power AC input voltage	170...264V rms single-phase (230V nom)	
Control power AC input current Nom (@ 230V AC) rms Max inrush (0-pk)	1.25 A 93.0 A ⁽²⁾	
Bus output voltage, nom	325V DC	
Line loss ride through	20 ms	
Continuous output current to bus (A_{DC})	9.67 A	6.42 A
Intermittent output current to bus (A_{DC}) ⁽³⁾	19.34 A	12.84 A
Bus overvoltage	425V DC	
Bus undervoltage	137.5V DC	
Internal shunt Continuous power Peak power	15 W 3000 W	
Internal shunt resistor	50 Ω	
Shunt on	405V	
Shunt off	375V	
Continuous power output to bus	3.0 kW	2.0 kW
Peak power output	6.0 kW	4.0 kW
Efficiency	95%	
Converter inductance	N/A	
Converter capacitance	540 μ F	
Converter leakage current (max)	2.0 mA	

(1) All 2093-AC05 integrated axis modules are limited to two contactor cycles per minute (with up to four axis modules), or one contactor cycle per minute (with five to eight axis modules).

(2) Maximum inrush duration is less than 1/2 line cycle.

(3) Intermittent output current duration equals 250 ms.

Kinetix 2000 Servo Drive Inverter Power Specifications

The following tables list power specifications for the inverter section that resides within an integrated axis module or an axis module.

Table 23 - IAM Inverter Power Specifications

Attribute	2093-AC05-MP1	2093-AC05-MP2	2093-AC05-MP5
Bandwidth Velocity Loop ⁽¹⁾ Current Loop	500 Hz 860 Hz		
PWM frequency	8 kHz		
Nominal input voltage	325V DC		
Continuous current (rms)	1.0 A	2.0 A	3.0 A
Continuous current (0-pk)	1.41 A	2.83 A	4.24 A
Peak current (rms)	3.0 A	6.0 A	9.0 A
Peak current (0-pk)	4.20 A	8.48 A	12.7 A
Peak output current time, max	3 s from 0% drive utilization (0% soak)		
Continuous power out, nom	0.3 kW	0.6 kW	0.9 kW
Efficiency	98%		
Capacitance	200 µF		
Capacitive energy absorption	7.5 J		
Inverter PCB leakage current	1 mA		

(1) Bandwidth values in the velocity loop vary based on tuning parameters and mechanical components.

Table 24 - AM Inverter Power Specifications

Specification	2093-AMP1	2093-AMP2	2093-AMP5	2093-AM01	2093-AM02
Bandwidth ⁽¹⁾ Velocity Loop Current Loop	500 Hz 860 Hz				
PWM frequency	8 kHz				
Nominal input voltage	325V dc				
Continuous current (rms)	1.0 A	2.0 A	3.0 A	6.0 A	9.5 A
Continuous current (0-pk)	1.41 A	2.83 A	4.24 A	8.48 A	13.4 A
Peak current (rms)	3.0 A	6.0 A	9.0 A	18.0 A	28.5 A
Peak current (0-pk)	4.20 A	8.48 A	12.7 A	25.5 A	40.3 A
Peak output current time (max)	3 seconds from 0% drive utilization (0% soak)				
Continuous power out (nom)	0.3 kW	0.6 kW	0.9 kW	1.9 kW	3.0 kW
Efficiency	98%				
Capacitance	200 µF			540 µF	
Capacitive energy absorption	7.5 J			20 J	
Inverter PCB leakage current	1 mA				

(1) Bandwidth values vary based on tuning parameters and mechanical components.

Kinetix 5500 Servo Drive Input Power Specifications

Table 25 - Kinetix 5500 Servo Drive Input Power Specifications

Attribute	2198-H003-ERSx	2198-H008-ERSx	2198-H015-ERSx	2198-H025-ERSx	2198-H040-ERSx	2198-H070-ERSx
AC input voltage	195...264V rms, single-phase (240V nom) 195...264V rms, three-phase (240V nom) 324...528V rms, three-phase (480V nom)			195...264V rms, three-phase (240V nom) 324...528V rms, three-phase (480V nom)		
AC input frequency	47...63 Hz					
Main AC input current ⁽¹⁾ Nom (rms) three-phase Nom (rms) single-phase	1.0 A 0.7 A	2.60 A 1.70 A	5.20 A 3.40 A	8.30 A N/A	13.4 A N/A	23.7 A N/A
Max inrush (0-pk)	15.0 A			30.0 A		60.0 A
Peak AC input current Nom (rms) three-phase Nom (rms) single-phase	3.0 A 2.1 A	7.8 A 5.1 A	15.6 A 10.2 A	24.9 A N/A	40.2 A N/A	71.1 A N/A
Line loss ride through	20 ms					
Control power DC input voltage	24V DC ±10%					
Control power DC input current ^{(1) (2)} (non-brake motors)	0.4 A _{DC}		0.8 A _{DC}			1.3 A _{DC}
Nominal bus output voltage	276...747V DC					
Continuous output current to bus Three-phase Single-phase	1.0 A _{DC} 0.67 A _{DC}	2.40 A _{DC} 1.60 A _{DC}	4.90 A _{DC} 3.27 A _{DC}	7.80 A _{DC} N/A	12.7 A _{DC} N/A	22.50 A _{DC} N/A
Peak output current to bus ⁽³⁾ Three-phase Single-phase	3.0 A _{DC} 2.0 A _{DC}	7.2 A _{DC} 4.8 A _{DC}	14.7 A _{DC} 9.8 A _{DC}	23.4 A _{DC} N/A	38.1 A _{DC} N/A	67.5 A _{DC} N/A
Continuous output power to bus 195...264V rms, single-phase 195...264V rms, three-phase 324...528V rms, three-phase	0.2 kW 0.3 kW 0.6 kW	0.5 kW 0.8 kW 1.6 kW	1.0 kW 1.6 kW 3.2 kW	N/A 2.5 kW 5.2 kW	N/A 4.0 kW 8.4 kW	N/A 7.2 kW 14.9 kW
Peak output power to bus 195...264V rms, single-phase 195...264V rms, three-phase 324...528V rms, three-phase	0.6 kW 1.0 kW 1.9 kW	1.6 kW 2.4 kW 4.9 kW	3.2 kW 4.9 kW 9.7 kW	N/A 7.8 kW 15.6 kW	N/A 12.7 kW 25.3 kW	N/A 22.4 kW 44.8 kW
DC input voltage (common bus follower)	276...747V DC					
DC input current (common bus follower)	1.0 A _{DC}	2.4 A _{DC}	4.9 A _{DC}	7.8 A _{DC}	12.7 A _{DC}	22.5 A _{DC}
Bus overvoltage	240V, nom AC input	440V DC				
	480V, nom AC input	810V DC				
Bus undervoltage	240V, nom AC input	138V DC				
	480V, nom AC input	275V DC				
Efficiency	97%					
Capacitive energy absorption	11.54 J		19.58 J	39.15 J	58.73 J	104.87 J
Short-circuit current rating	150,000 A (rms) symmetrical					

(1) All drives are limited to 1 power cycle per minute.

(2) For current values when motors include a holding brake and additional information, see [Control Power Specifications on page 57](#).

(3) Peak output current duration equals 1.0 second.

Kinetix 5500 Servo Drive Output Power Specifications

Table 26 - Kinetix 5500 Servo Drive Output Power Specifications

Attribute	2198-H003-ERSx	2198-H008-ERSx	2198-H015-ERSx	2198-H025-ERSx	2198-H040-ERSx	2198-H070-ERSx
Bandwidth ⁽¹⁾ Velocity loop, max Current loop	300 Hz 1000 Hz					
Continuous output current (rms)	1.0 A	2.5 A	5.0 A	8.0 A	13.0 A	23.0 A
Continuous output current (0-pk)	1.4 A	3.5 A	7.1 A	11.3 A	18.4 A	32.5 A
Peak output current (rms) ⁽²⁾	2.5 A	6.25 A	12.5 A	20.0 A	32.5 A	57.5 A
Peak output current (0-pk) ⁽²⁾	3.5 A	8.8 A	17.7 A	28.3 A	45.9A	81.3A
Continuous power out (nom) 195...264V rms, single-phase 195...264V rms, three-phase 324...528V rms, three-phase	0.2 kW 0.3 kW 0.6 kW	0.5 kW 0.8 kW 1.6 kW	1.0 kW 1.5 kW 3.2 kW	N/A 2.4 kW 5.1 kW	N/A 4.0 kW 8.3 kW	N/A 7.0 kW 14.6 kW
Internal shunt resistance	100 Ω		60 Ω			40 Ω
Internal shunt power	30 W		50 W			75 W
Shunt on	775V plus 30V x bus regulator capacity/utilization ⁽³⁾					
Shunt off	765V plus 30V x bus regulator capacity/utilization ⁽³⁾					

(1) Bandwidth values vary based on tuning parameters and mechanical components.

(2) Peak current duration (T_{PKmax}) equals 1.0 second.

(3) The shunt on and shunt off voltages increase during periods of shunting activity to promote sharing of shunt power in multi-axis configurations. Shunt utilization is equivalent to the BusRegulatorCapacity tag in the Logix Designer application.

Control Power Specifications **Kinetix 2000 Servo Drive Control Power Specifications**

This section lists auxiliary control power requirements for a Kinetix 2000 servo drive system comprised of an IAM, up to seven AMs, a Shunt Module, or a Slot Filler.

Table 27 - Auxiliary Control Power Specifications

Number of AMs (2093-AMPx or 2093-AMx)	Current Requirements (115V AC)	Current Requirements (230V AC)	Max Inrush	Input VA
0	0.3 A	0.15 A	93 A	50 VA
1	0.6 A	0.30 A		99 VA
2	0.9 A	0.45 A		148 VA
3	1.2 A	0.60 A		197 VA
4	1.5 A	0.75 A		247 VA
5	1.8 A	0.90 A		296 VA
6	2.1 A	1.05 A		345 VA
7	2.4 A	1.20 A		395 VA
Shunt Module (2093-ASP06)	2.5 A	1.25 A		410 VA
Slot Filler (2093-PRF)	—	—	—	—

Kinetix 5500 Servo Drive Control Power Specifications

Table 28 - Control Power Current Specifications

Cat. No.	24V Current (non-brake motor)	24V Current (2 A brake motor)	24V Inrush Current ⁽¹⁾
2198-H003-ERSx	0.4 A DC	2.4 A DC	2.0 A
2198-H008-ERSx			
2198-H015-ERSx	0.8 A DC	2.8 A DC	3.0
2198-H025-ERSx			
2198-H040-ERSx			
2198-H070-ERSx	1.3 A DC	3.3 A DC	
2198-CAPMOD-1300	0.3 A DC	N/A	2.0

(1) Inrush current duration is less than 30 ms.

Power Dissipation Specifications

Kinetix 2000 Servo Drive Power Dissipation Specifications

Use the following table to size an enclosure and calculate required ventilation for a Kinetix 2000 servo drive system.

Kinetix 2000 Servo Drive Modules		Usage as a Percentage of Rated Power Output (Watts)				
		20%	40%	60%	80%	100%
Converter (IAM) ⁽¹⁾						
2093-AC05-MP1	Three-phase	7.0	10.5	14.0	17.4	20.9
2093-AC05-MP2						
2093-AC09-MP5						
2093-AC05-MP1	Single-phase	5.8	8.0	10.3	12.6	14.8
2093-AC05-MP2						
2093-AC09-MP5						
Inverter (IAM and AM) ⁽¹⁾						
2093-AC05-MP1 and 2093-AMP1		31.6	33.6	35.6	37.6	39.6
2093-AC05-MP2 and 2093-AMP2		33.0	36.4	39.8	43.3	46.8
2093-AC05-MP5 and 2093-AMP5		36.2	42.9	49.8	56.8	63.9
2093-AM01		38.3	46.7	55.3	64.1	73.1
2093-AM02		44.3	55.6	67.3	79.2	91.4
Shunt module (SM)						
2093-ASP06		35.8	45.8	55.8	65.8	75.8
Power Rail						
2093-PRSxx		0	0	0	0	0
Connector Kit						
2093-K2CK-D15M		0	0	0	0	0

(1) Internal shunt power is not included in the calculations and must be added based on utilization.

Kinetix 5500 Servo Drive Power Dissipation Specifications

Use this table to size an enclosure and calculate required ventilation for a Kinetix 5500 drive system.

Kinetix 5500 Servo Drive Cat. No.	Usage as % of Rated Power Output (Watts)				
	20%	40%	60%	80%	100%
2198-H003-ERSx	12	25	37	50	62
2198-H008-ERSx					
2198-H015-ERSx	40	80	120	160	200
2198-H025-ERSx					
2198-H040-ERSx					
2198-H070-ERSx	64	128	192	256	320

Cable Lengths

Kinetix 2000 Servo Drive Feedback Cable Lengths

Table 29 - MP-Series, Y-Series, and TL-Series Motors/Actuators

MPL-A (230V) Motors ⁽¹⁾		MPG-A, MPF-A, and MPS-A (230V) Motors ⁽²⁾	MPAI-A (230V) Linear Actuators ⁽³⁾	Y-Series (230V) Motors ⁽⁴⁾	TL-Series (230V) Motors ⁽⁵⁾	
Absolute High-resolution	Incremental	Absolute High-resolution	Absolute High-resolution	Incremental	Absolute High-resolution	Incremental
30 m (98.4 ft)	30 m (98.4 ft)	30 m (98.4 ft)	30 m (98.4 ft)	30 m (98.4 ft)	30 m (98.4 ft)	30 m (98.4 ft)

- (1) Refers to MPL-AxxxxS/M and E/V (single-turn or multi-turn) low-inertia motors with absolute high-resolution feedback.
Refers to MPL-AxxxxH low-inertia motors with 2000-line incremental feedback.
- (2) Refers to MPG-AxxxxS/M (single-turn or multi-turn) integrated rotary actuators with absolute high-resolution feedback.
Refers to MPF-AxxxxS/M (single-turn or multi-turn) food-grade motors with absolute high-resolution feedback.
Refers to MPS-AxxxxS/M (single-turn or multi-turn) stainless-steel motors with absolute high-resolution feedback.
- (3) Refers to MPAI-AxxxxV/M (multi-turn) integrated linear actuators with absolute high-resolution feedback.
- (4) Refers to Y-Series motors with incremental (optical encoder) feedback.
- (5) Refers to TL-Axxxx-B low-inertia motors with absolute high-resolution feedback.
Refers to TL-Axxxx-H low-inertia motors with incremental feedback.

Kinetix 5500 Servo Drive Single Motor Cable Lengths

Although single motor cables are available in standard lengths up to 50 m (164 ft), use of continuous-flex cables limits the maximum cable length. This table assumes the use of 2090-Series single motor cables. See the Kinetix Motion Accessories Technical Data, publication [GMC-TD004](#), for cable specifications.

Kinetix 5500 Servo Drive Cat. No.	Standard (non-flex) Cables Cat. No. 2090-CSxM1DF-xxAAxx	Continuous-flex Cables Cat. No. 2090-CSBM1DF-xxAFxx
2198-H003-ERSx 2198-H008-ERSx	50 m (164 ft)	30 m (98.4 ft)
2198-H015-ERS x 2198-H025-ERS x 2198-H040-ERSx	50 m (164 ft)	
2198-H070-ERSx	50 m (164 ft)	

Combined cable length for all axes on the same DC bus must not exceed 250 m (820 ft). Drive-to-motor cables must not exceed 50 m (164 ft).

IMPORTANT System performance was tested at these cable length specifications. These limitations also apply when meeting CE requirements.

Environmental Specifications Kinetix 2000 Servo Drive Environmental Specifications

Attribute	Operational Range	Storage Range (non-operating)
Ambient Temperature	0...50 °C (32...122 °F)	-40...85 °C (-40...185 °F)
Relative Humidity	5...95% noncondensing	5...95% noncondensing
Altitude	1000 m (3281 ft) 3000 m (9843 ft) with derating ⁽¹⁾	3000 m (9843 ft) during transport
Environmental Rating	IP2X (EN60529) For use only in a Pollution Degree 2 Environment (UL508c, section 2.7) Open Device (UL508c, section 2.5)	
Vibration	5...55 Hz @ 0.35 mm (0.014 in.) double amplitude, continuous displacement; 55...500 Hz @ 2.0 g peak constant acceleration	
Shock	15 g, 11 ms half-sine pulse (3 pulses in each direction of 3 mutually perpendicular directions)	
Conformal Coating	IB31: DSP and SERCOS pins, anti-dust and anti-humidity 1B73LSE: Power Rail connector pins, Converter, Inverter, Shunt, Power Rail, and Slot Filler PCB assemblies, clear UL creepage and clearance issue.	

(1) Peak current output is derated by 15% for each 1000 m over 1000 m (3281 ft).

Kinetix 5500 Servo Drive Environmental Specifications

Attribute	Operational Range	Storage Range (nonoperating)
Ambient temperature	0...50 °C (32...122 °F)	-40...70 °C (-40...158 °F)
Relative humidity	5...95% noncondensing	5...95% noncondensing
Altitude	1000 m (3281 ft)	3000 m (9843 ft) during transport
Vibration	5...55 Hz @ 0.35 mm (0.014 in.) double amplitude, continuous displacement; 55...500 Hz @ 2.0 g peak constant acceleration	
Shock	15 g, 11 ms half-sine pulse (3 pulses in each direction of 3 mutually perpendicular directions)	

Certifications**Kinetix 2000 Servo Drive Certifications**

Certification ⁽¹⁾ (when product is marked)	Standards
c-UL-us	UL Listed to U.S. and Canadian safety standards (UL 508 C File E226834).
CE	European Union 89/336/EEC EMC Directive compliant with EN 61800-3:2004: Adjustable Speed Electrical Power Drive Systems - Part 3; EMC Product Standard including specific test methods. European Union 73/23/EEC Low Voltage Directive compliant with: <ul style="list-style-type: none"> EN 60204-1:1997 - Safety of Machinery - Electrical Equipment of Machines. EN 50178:1997 - Electronic Equipment for use in Power Installations.
Functional Safety	<ul style="list-style-type: none"> EN 60204-1:1997 - Safety of Machinery - Electrical Equipment of Machines. IEC 61508: Part 1-7:2000 - Functional Safety of Electrical/Electronic/Programmable Electronic Safety-related Systems. EN954-1:1996 - Safety of machinery. Safety related parts of control systems. Part 1: General principles for design.

(1) See <http://www.rockwellautomation.com/products/certification> for Declarations of Conformity Certificates.

Kinetix 5500 Servo Drive Certifications

Agency Certification ⁽¹⁾	Standards
c-UL-us ⁽²⁾	UL Listed to U.S. and Canadian safety standards (UL 508C File E59272). Solid-state motor overload protection provides dynamic fold-back of motor current when 110% of the motor rating is reached with a peak current limit based on the peak rating of the motor as investigated by UL to comply with UL 508C (UL File E59272).
CE	European Union 2004/108/EC EMC Directive compliant with EN 61800-3:2004: Adjustable Speed Electrical Power Drive Systems - Part 3; EMC Product Standard including specific test methods. European Union 2006/95/EC Low Voltage Directive compliant with EN 61800-5-1:2007 - Adjustable speed electrical power drive systems.
Functional Safety	TÜV Certified for Functional Safety: up to SIL CL2, according to EN 61800-5-2, EN 61508, and EN 62061; up to Performance Level PLd and Category 3, according to EN ISO 13849-1; when used as described in the Kinetix 5500 Servo Drives User Manual, publication 2198-UM001 .
C-Tick	Australian Radio Communications Act, compliant with: <ul style="list-style-type: none"> Radio Communications Act: 1992 Radio Communications (Electromagnetic Compatibility) Standard: 1998 Radio Communications (Compliance Labelling - Incidental Emissions) Notice: 1998 AS/NZS CISPR 11: 2002 (Group 1, Class A)
KC	Korean Registration of Broadcasting and Communications Equipment, compliant with: <ul style="list-style-type: none"> Article 58-2 of Radio Waves Act, Clause 3 Registration number: KCC-REM-RAA-2198
ODVA	EtherNet/IP conformance tested.
OSHA	Maximum audible noise from the servo drive system complies with OSHA standard 3074, Hearing Conservation (<85 dBA).

(1) When product is marked, see <http://www.ab.com> for Declarations of Conformity Certificates.

(2) UL has not evaluated the safe-off, safe torque-off, or safe speed-monitoring options in these products.

Notes:

Interconnect Diagrams

Kinetix 2000 Servo Drive Examples

This section provides wiring examples to assist you in wiring the Kinetix 2000 servo drive system.

Power Wiring Examples

Figure 5 - Single IAM Wiring Example with LIM 2094-AL09

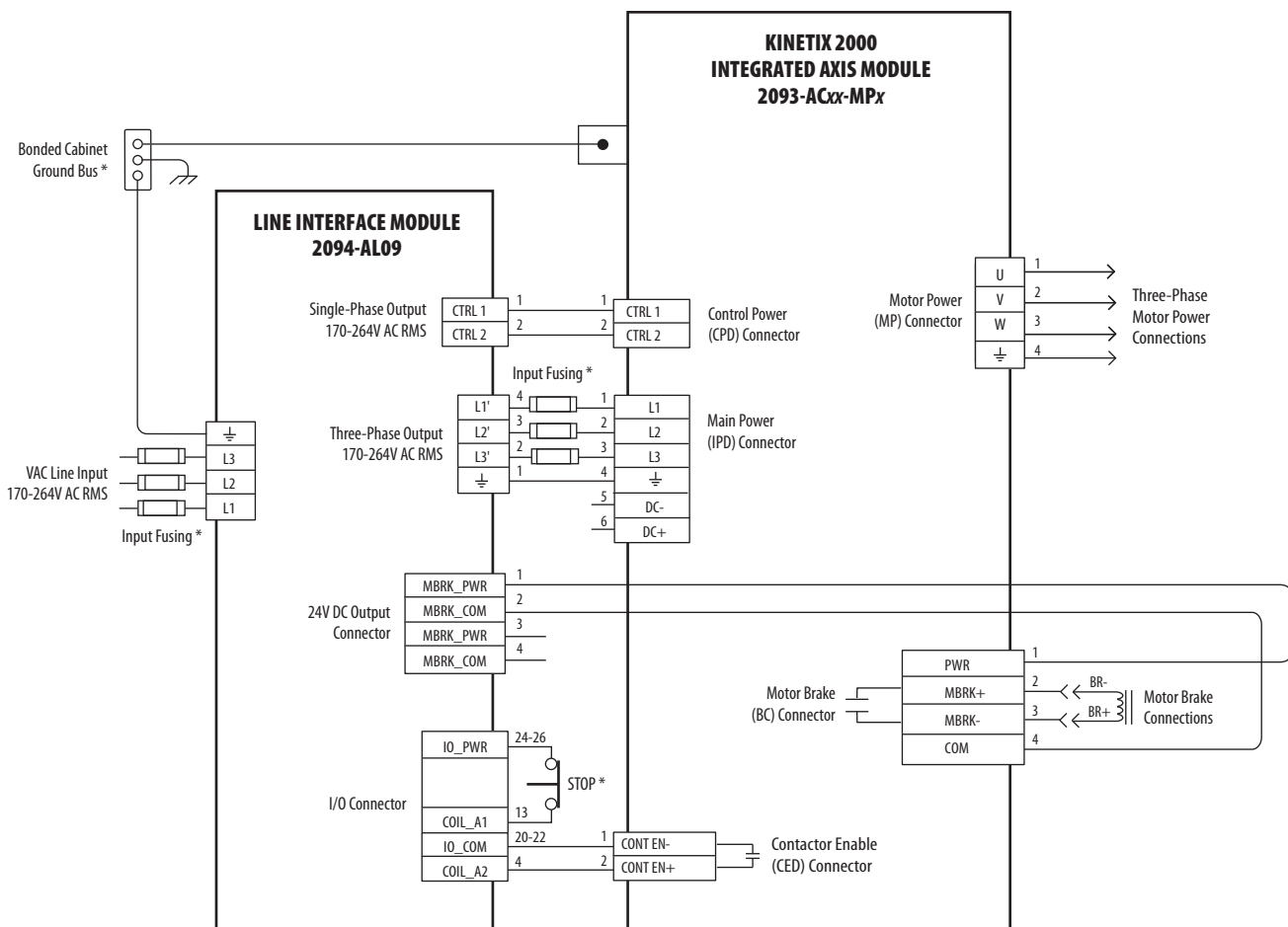

* INDICATES USER-SUPPLIED COMPONENT

The configuration on this page does not include a LIM. You must supply input power components. The single-phase and three-phase line filters are wired downstream of fusing and the M1 contactor.



ATTENTION: Wiring the contactor enable (CED) relay is required. To avoid injury or damage to the drive, wire the contactor enable relay into your safety control string.

Figure 6 - Three-Phase Power Input (without LIM) to IAM Wiring Example

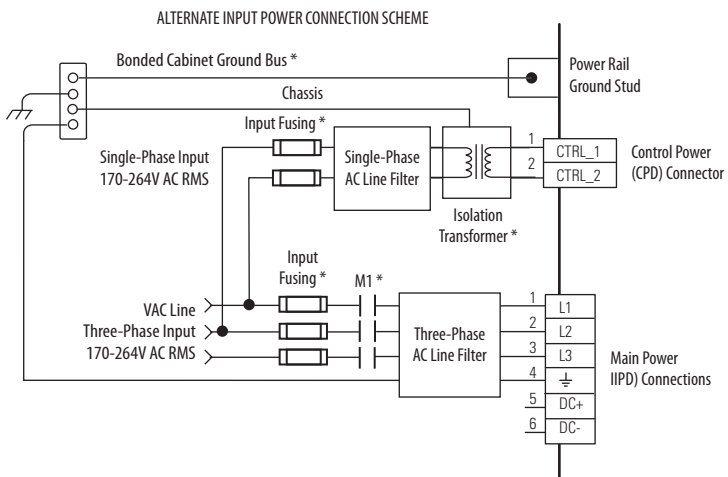
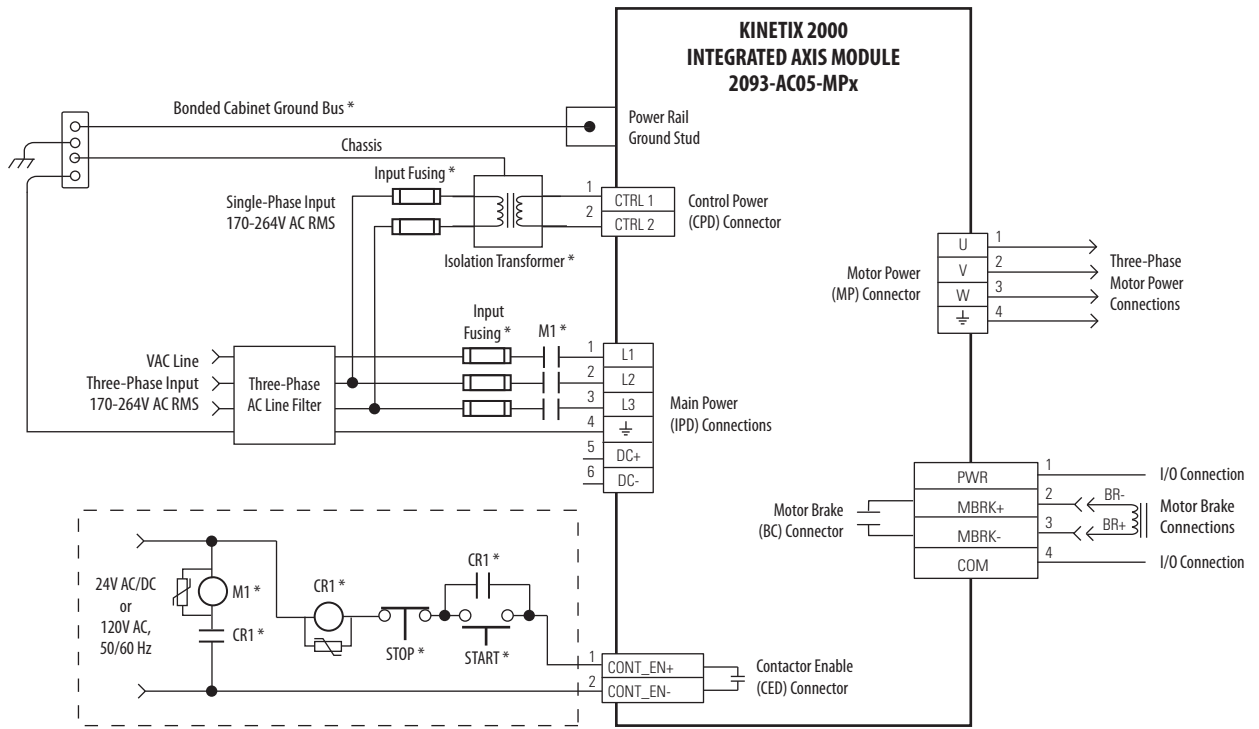

* INDICATES USER-SUPPLIED COMPONENT

The configuration on this page does not include a LIM. You must supply input power components. The single-phase and three-phase line filters are wired downstream of fusing and the M1 contactor.



ATTENTION: Wiring the contactor enable (CED) relay is required. To avoid injury or damage to the drive, wire the contactor enable relay into your safety control string.

Figure 7 - Single-Phase Power Input (without LIM) to IAM Wiring Example

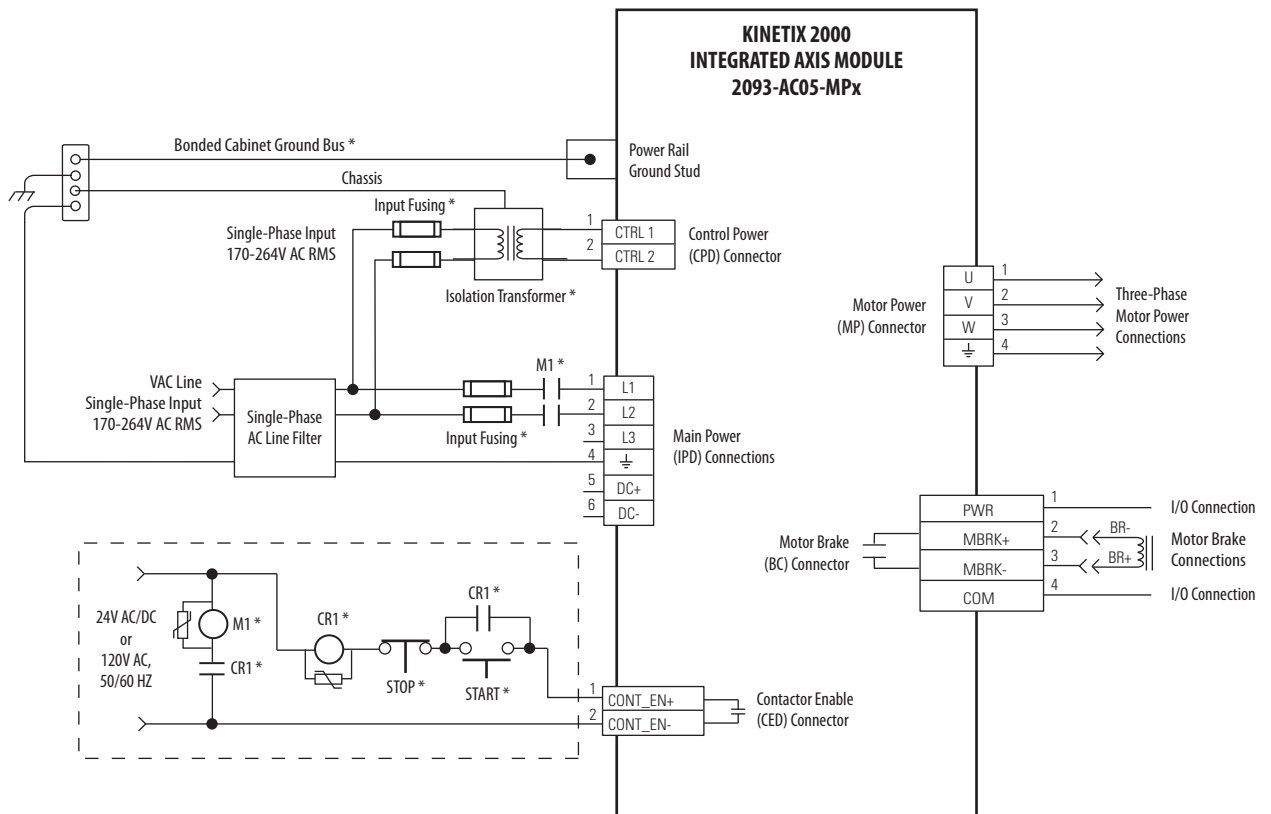

ALTERNATE INPUT POWER CONNECTION SCHEME

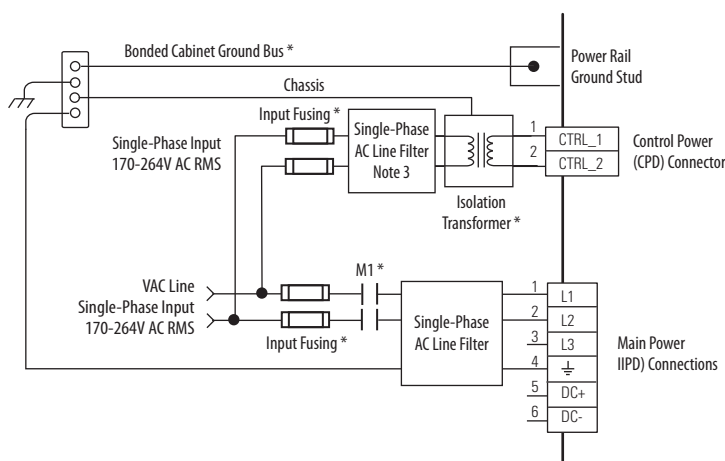

* INDICATES USER-SUPPLIED COMPONENT

DC Common Bus Wiring Examples

Figure 8 - Leader IAM Wiring Example with Single Follower IAM

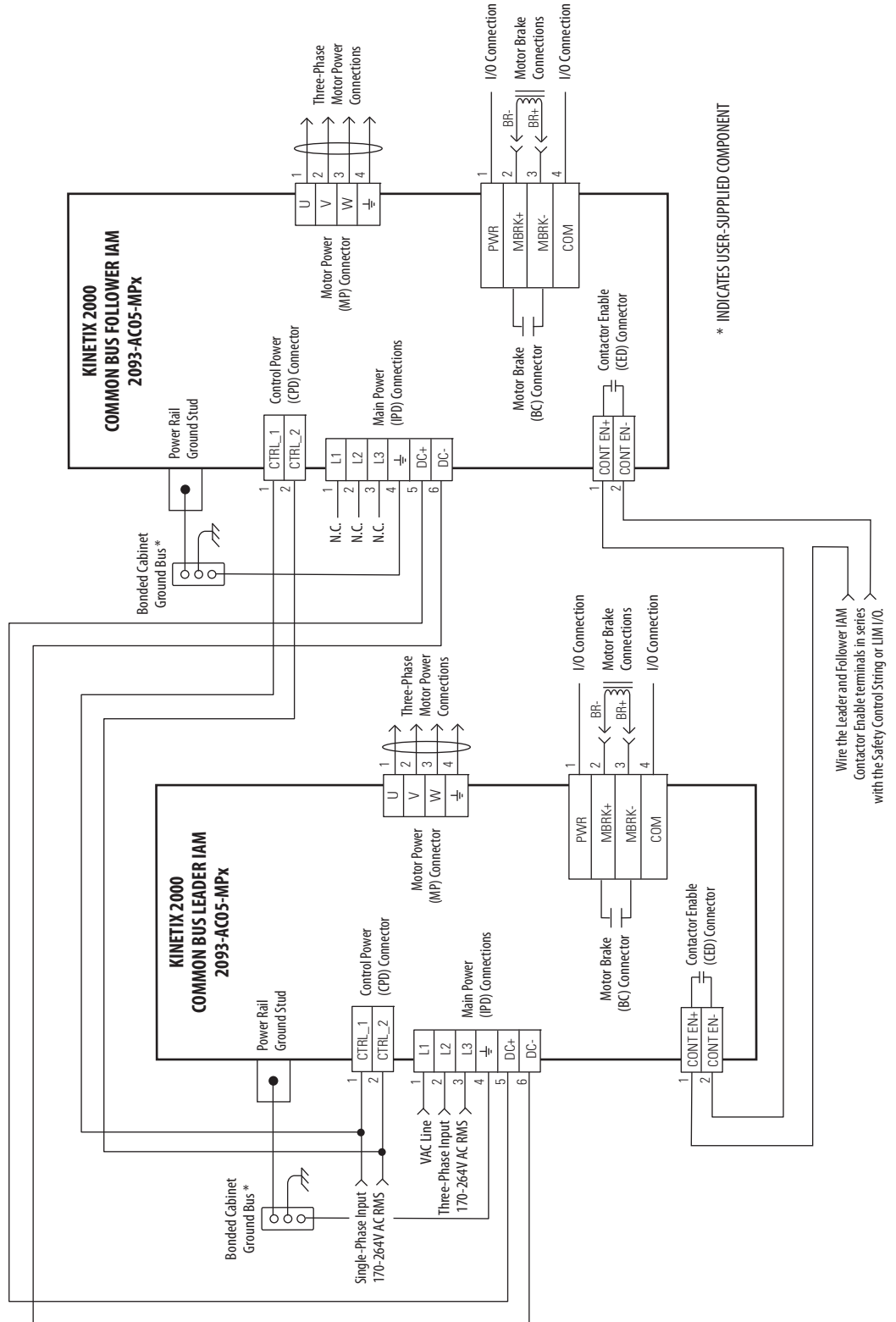

Kinetix 5500 Servo Drive Power Wiring Examples

This section provides wiring examples to assist you in wiring the Kinetix 5500 servo drive system.

You must supply input power components. The single-phase and three-phase line filters are wired downstream of the input fusing.

Single-axis Drive Wiring Examples

Figure 9 - Kinetix 5500 Servo Drives Power Wiring (three-phase operation)

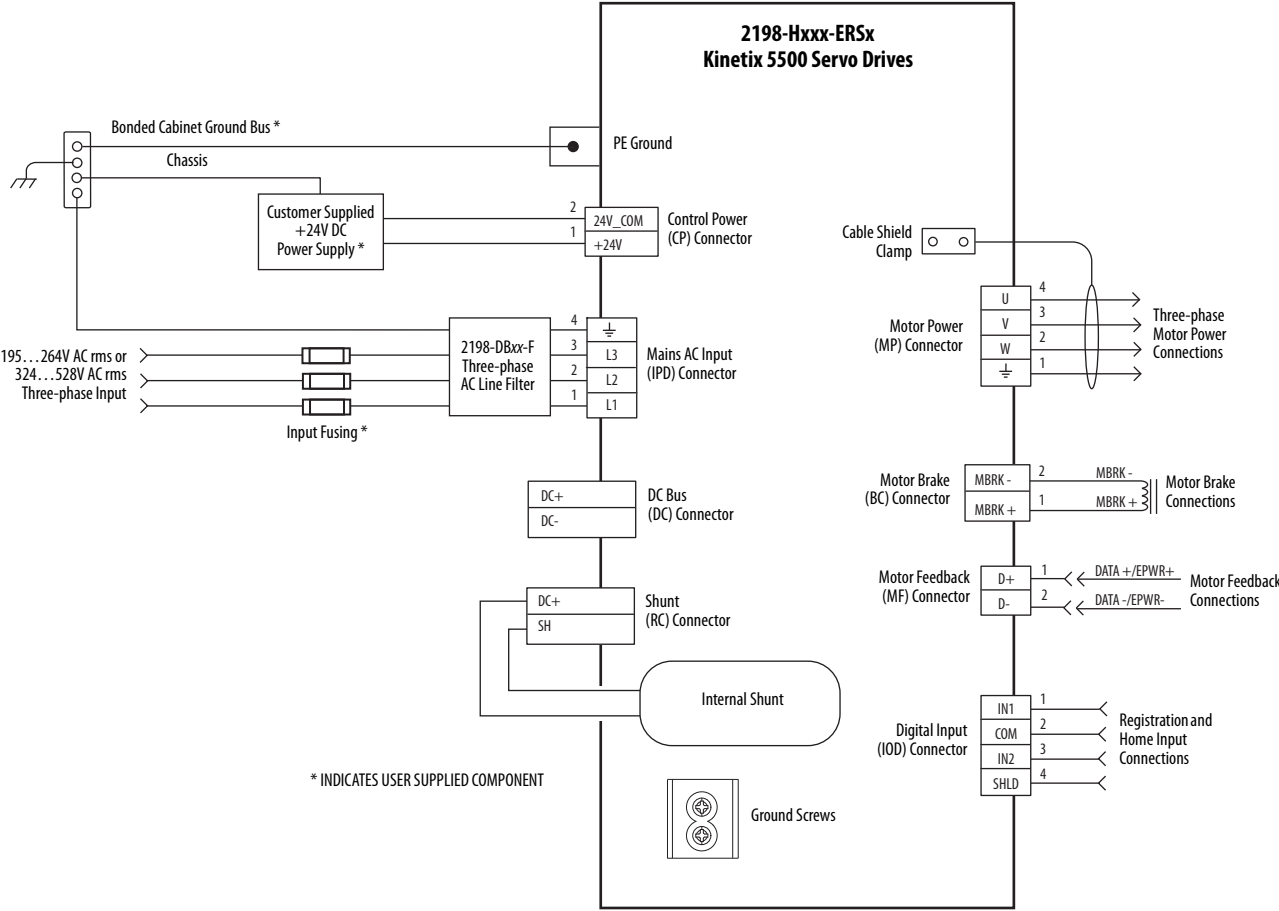
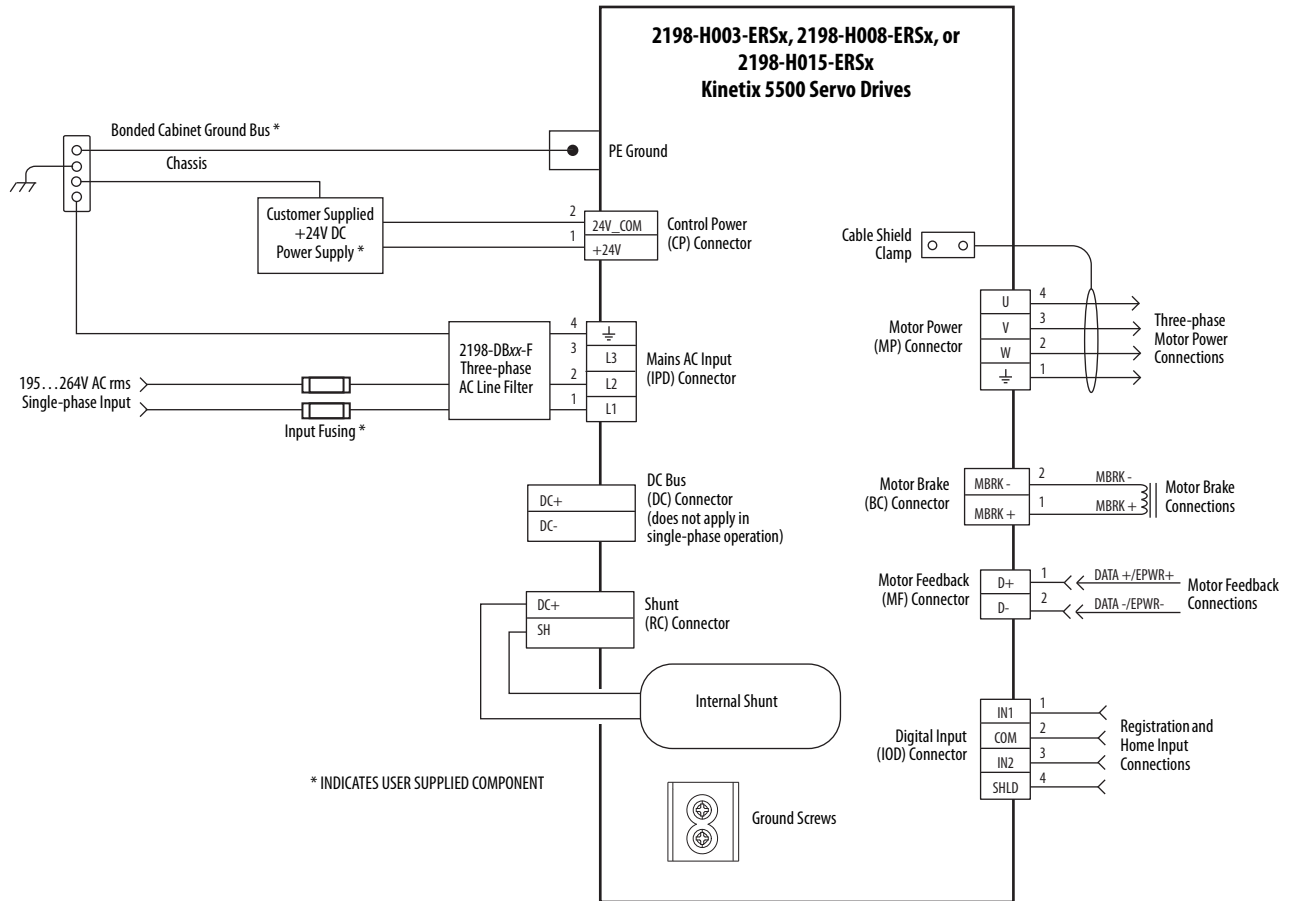

Figure 10 - Kinetix 5500 Servo Drives Power Wiring (single-phase operation)



Bus-sharing Wiring Examples

For bus-sharing configurations, use the 2198-H0x0-xx-x shared-bus connection system to extend power from drive to drive.

Figure 11 - Kinetix 5500 Servo Drives with Shared AC Bus

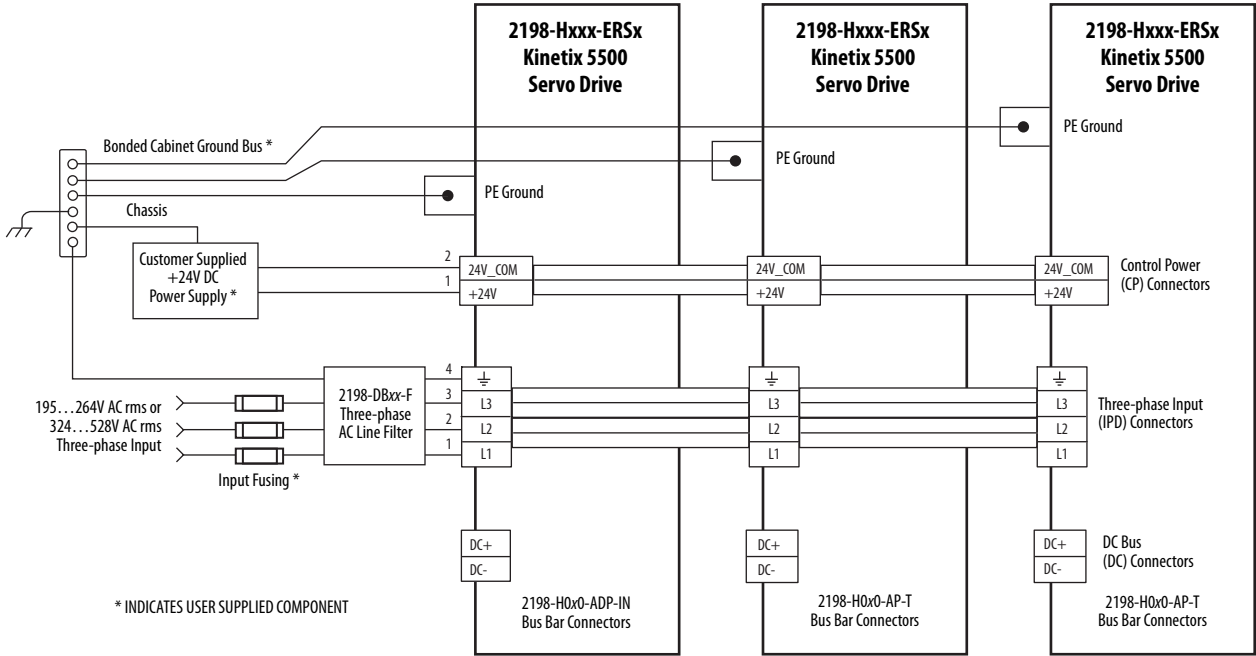

Figure 12 - Kinetix 5500 Servo Drives with Shared AC/DC Bus

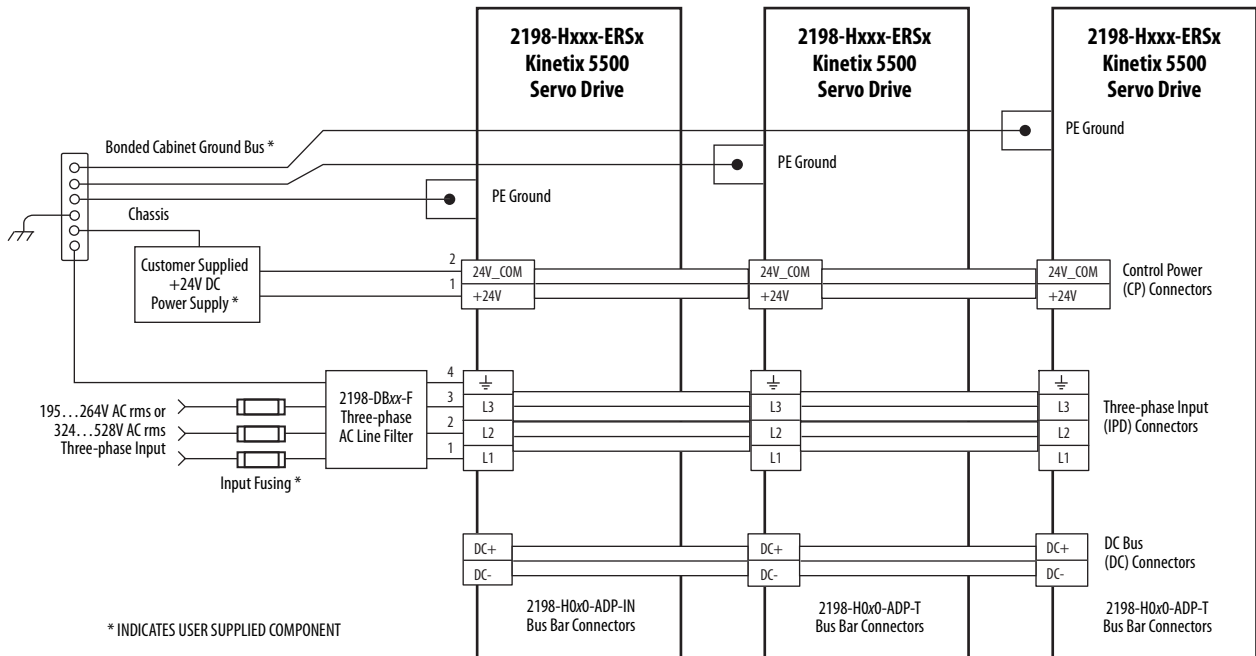

Figure 13 - Kinetix 5500 Servo Drives with Shared DC (common bus)

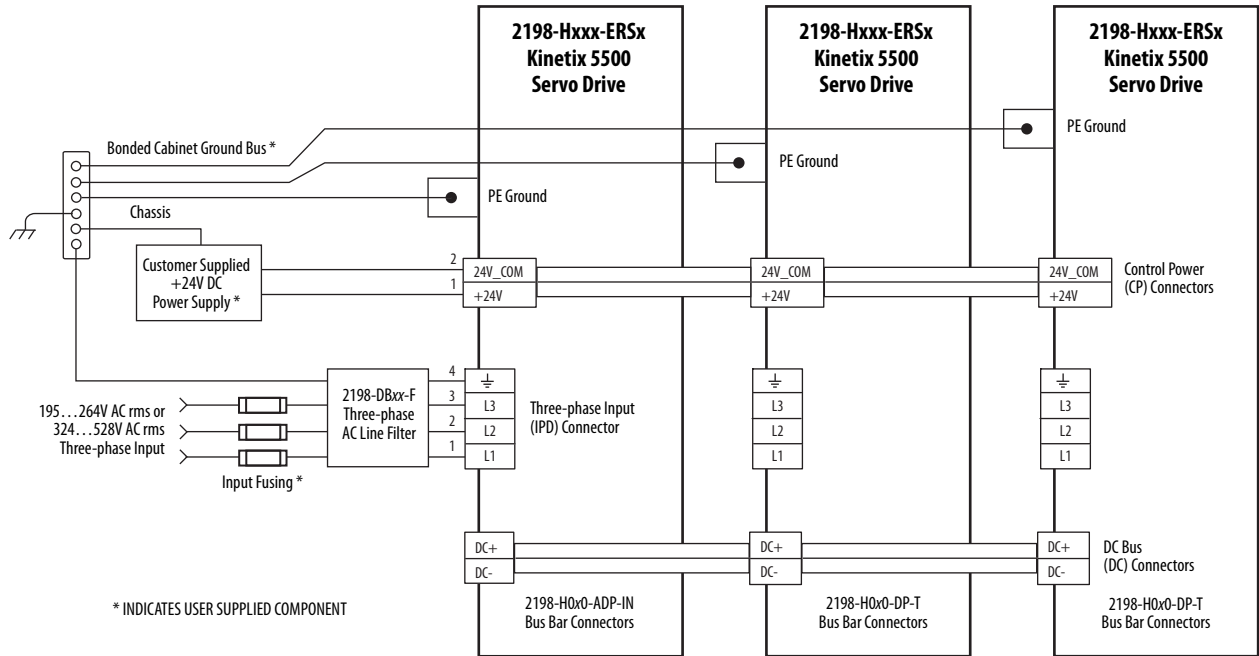
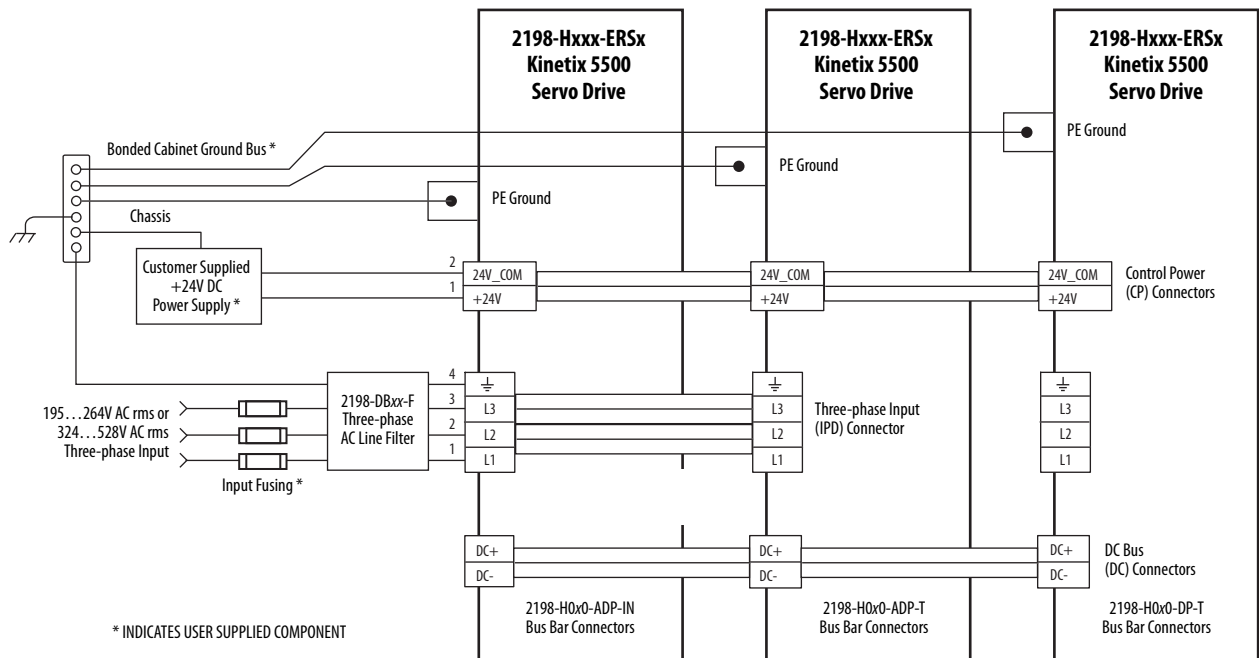

Figure 14 - Kinetix 5500 Servo Drives with Shared AC/DC Hybrid Bus



Communication Configurations

The Kinetix 5500 servo drives support any Ethernet topology including linear, ring, and star.

These examples feature the CompactLogix 5370 programmable automation controllers (catalog number 1769-L36ERM) with support for Integrated Motion over the EtherNet/IP network. Controller features include the following:

- Supports up to 16 axes
- Supports up to 48 devices in linear configurations
- Dual-port connectivity to support device-level ring (DLR) topology

See the CompactLogix Controllers Specifications Technical Data, publication [1769-TD005](#), for more information on CompactLogix 5370 L1, L2, and L3 controllers.

Kinetix 5500 Servo Drive Linear Topology

In this example, all devices are connected in linear topology. The Kinetix 5500 servo drives include dual-port connectivity, however, if any device becomes disconnected, all devices downstream of that device lose communication. Devices without dual ports must include the 1783-ETAP module or be connected at the end of the line.

Figure 15 - Kinetix 5500 Servo Drive Linear Communication Installation

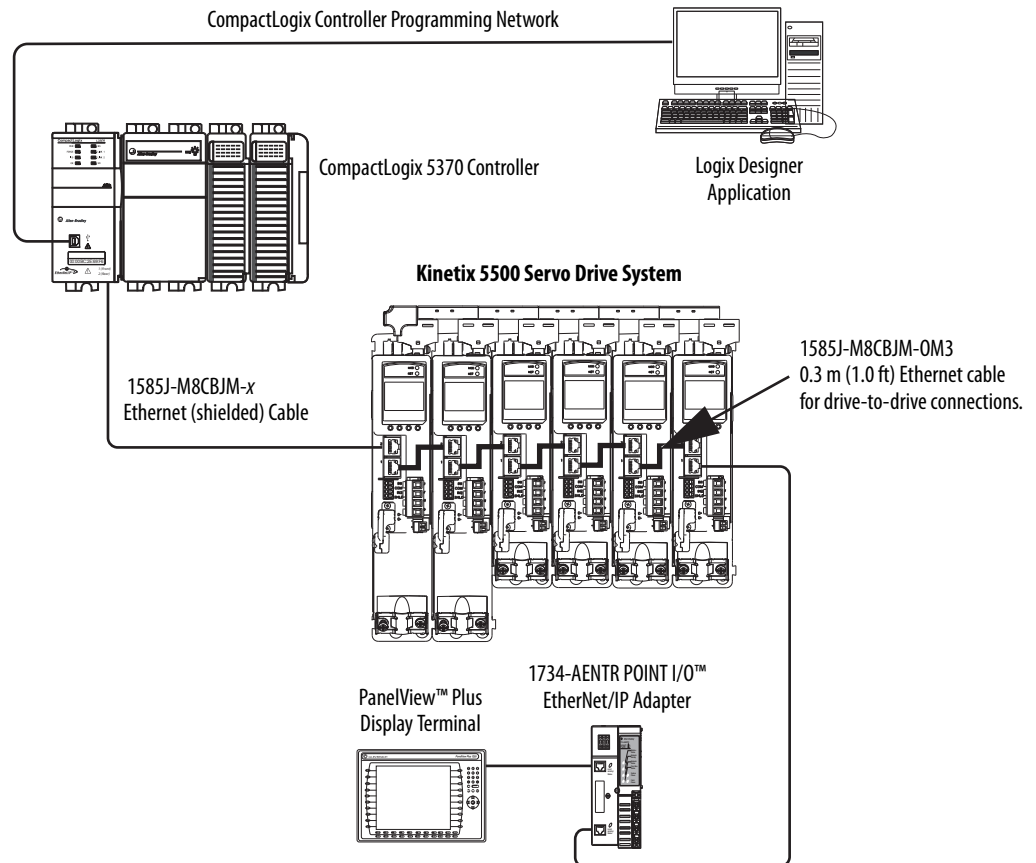

Kinetix 5500 Servo Drive Ring Topology

In this example, the devices are connected by using ring topology. If only one device in the ring is disconnected, the rest of the devices continue to communicate. For ring topology to work correctly, a device level ring (DLR) supervisor is required (for example, the Bulletin 1783 ETAP device). DLR is an ODVA standard. For more information, see the EtherNet/IP Embedded Switch Technology Application Guide, publication [ENET-AP005](#).

Devices without dual ports require a DLR supervisor, for example the 1783-ETAP module, to complete the network ring.

Figure 16 - Kinetix 5500 Servo Drive Ring Communication Installation

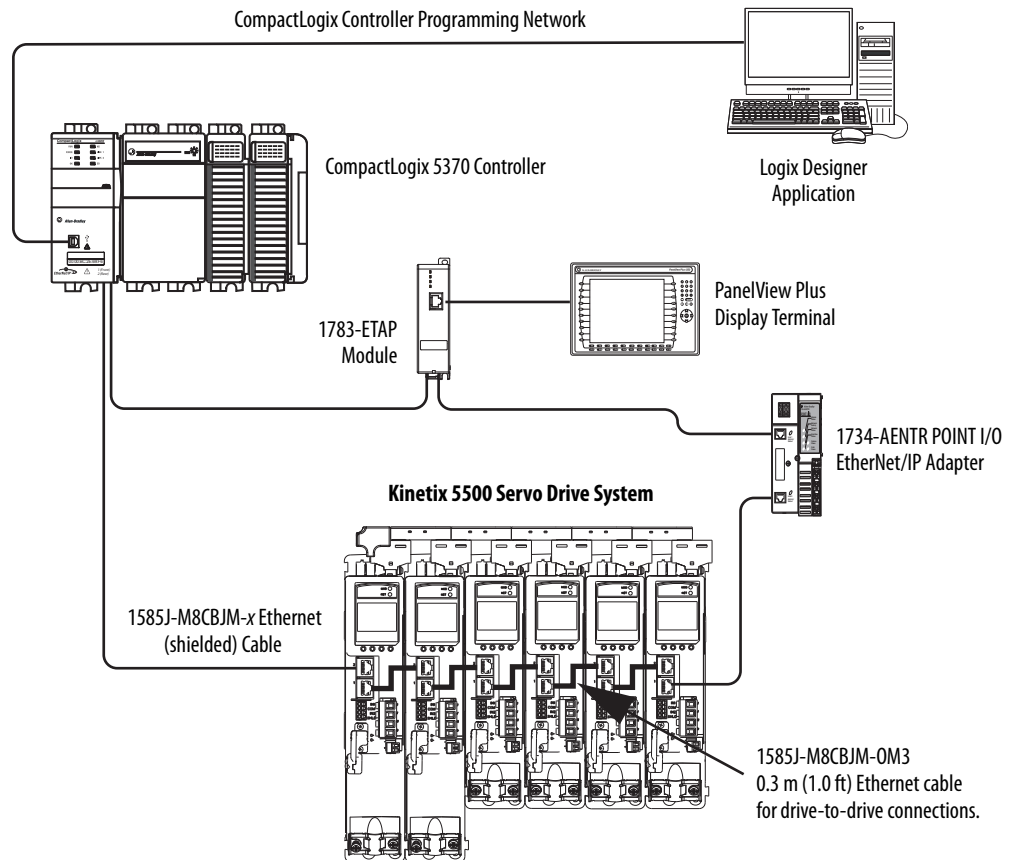

Kinetix 5500 Servo Drive Star Topology

In this example, the devices are connected by using star topology. Each device is connected directly to the switch.

Kinetix 5500 servo drives have dual ports, so linear topology is maintained from drive-to-drive, but Kinetix 5500 servo drives and other devices operate independently. The loss of one device does not impact the operation of other devices.

Figure 17 - Kinetix 5500 Servo Drive Star Communication Installation

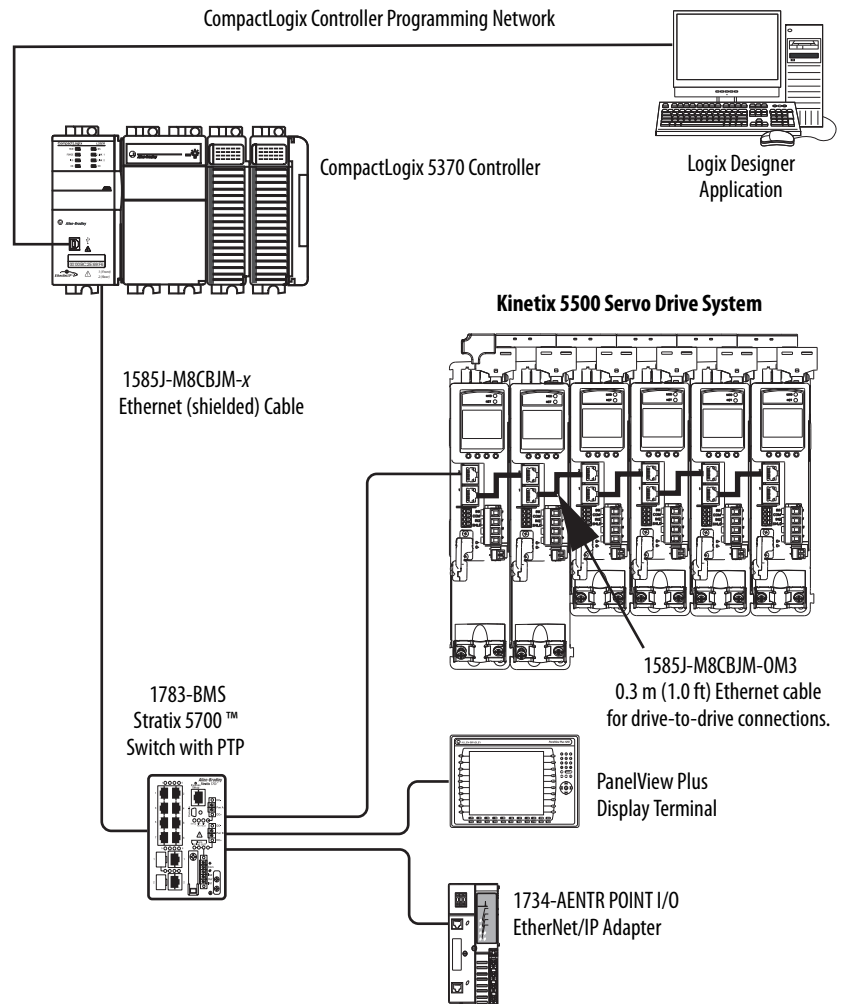

Rockwell Automation Support

Rockwell Automation provides technical information on the Web to assist you in using its products.

At <http://www.rockwellautomation.com/support> you can find technical and application notes, sample code, and links to software service packs. You can also visit our Support Center at <https://rockwellautomation.custhelp.com/> for software updates, support chats and forums, technical information, FAQs, and to sign up for product notification updates.

In addition, we offer multiple support programs for installation, configuration, and troubleshooting. For more information, contact your local distributor or Rockwell Automation representative, or visit <http://www.rockwellautomation.com/services/online-phone>.

Installation Assistance

If you experience a problem within the first 24 hours of installation, review the information that is contained in this manual. You can contact Customer Support for initial help in getting your product up and running.

United States or Canada	1.440.646.3434
Outside United States or Canada	Use the Worldwide Locator at http://www.rockwellautomation.com/rockwellautomation/support/overview.page , or contact your local Rockwell Automation representative.

New Product Satisfaction Return

Rockwell Automation tests all of its products to help ensure that they are fully operational when shipped from the manufacturing facility. However, if your product is not functioning and needs to be returned, follow these procedures.

United States	Contact your distributor. You must provide a Customer Support case number (call the phone number above to obtain one) to your distributor to complete the return process.
Outside United States	Please contact your local Rockwell Automation representative for the return procedure.

Documentation Feedback

Your comments will help us serve your documentation needs better. If you have any suggestions on how to improve this document, complete this form, publication [RA-DU002](#), available at <http://www.rockwellautomation.com/literature/>.

Rockwell Otomasyon Ticaret A.Ş., Kar Plaza İş Merkezi E Blok Kat:6 34752 İçerenköy, İstanbul, Tel: +90 (216) 5698400

www.rockwellautomation.com

Power, Control and Information Solutions Headquarters

Americas: Rockwell Automation, 1201 South Second Street, Milwaukee, WI 53204-2496 USA, Tel: (1) 414.382.2000, Fax: (1) 414.382.4444
Europe/Middle East/Africa: Rockwell Automation NV, Pegasus Park, De Kleetlaan 12a, 1831 Diegem, Belgium, Tel: (32) 2 663 0600, Fax: (32) 2 663 0640
Asia Pacific: Rockwell Automation, Level 14, Core F, Cyberport 3, 100 Cyberport Road, Hong Kong, Tel: (852) 2887 4788, Fax: (852) 2508 1846